

2023/08-1



EURLEY

SPIRAL BORU ÜRETİMİNDE VERİMLİ ÇÖZÜMLER

**EFFICIENT SOLUTIONS FOR
SPIRAL PIPE PRODUCTION**





SPIRAL BORU UÇLARI

SPIRAL PIPE INSERTS

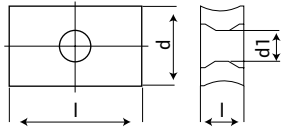
 Kenar Frezeleme Uçları
Sheet Edge Proportion, Milling Insert

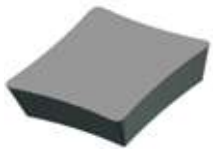
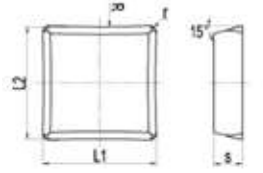
LOCX	Sipariş Kodu Order Code	l	d	t	d1	r	
	LOCX3010Z	30	18,3	10	6,8	-	

SDMN	Sipariş Kodu Order Code	L1	L2	S	R	r	
	SDMN2507-R0	25.4	-	6.35	-	1.6	
	SDMN2507-R105	25.4	23.87	6.35	105	1.6	
	SDMN2507-R120	25.4	24.0	6.35	120	1.6	
	SDMN2507-R180	25.4	24.34	6.35	180	1.6	
	SDMN2507-R300	25.4	24.98	6.35	300	1.6	
	SDMN2507-R340	25.4	25.04	6.35	340	1.6	
	SDMN2507-400	25.4	25.1	6.35	400	1.6	
	SDMN2507-R550	25.4	25.18	6.35	550	1.6	

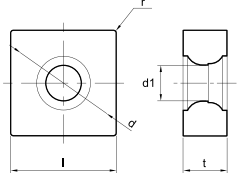
SNHQ	Sipariş Kodu Order Code	l	d	t	d1	r	
	SNHQ150704S	15,875	15,875	7,94	5,8	0,4	
	SNHQ 190704S	19,05	19,05	7,94	6,4	0,4	
	SNHQ 200700S	20,00	20,00	7,00	6,4	0,0	

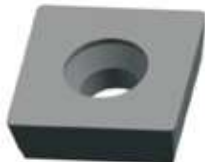
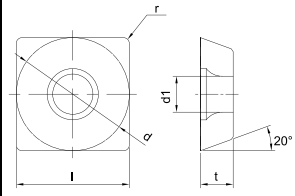

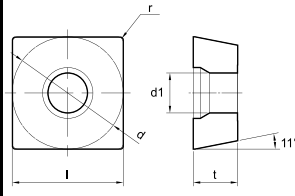
SEEW	Sipariş Kodu Order Code	l	d	t	d1	r	
	SEEW22	22	22	6,35	5,8	0,3	



SPEW	Sipariş Kodu Order Code	l	d	t	d1	r	
	SPEW190608	19	19	6,35	6,6	0,8	

SPIRAL BORU UÇLARI

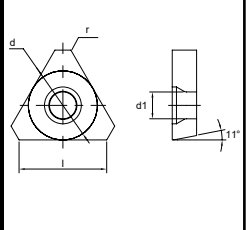
SPIRAL PIPE INSERTS

 Kenar Frezeleme Uçları
Sheet Edge Proportion, Milling Insert

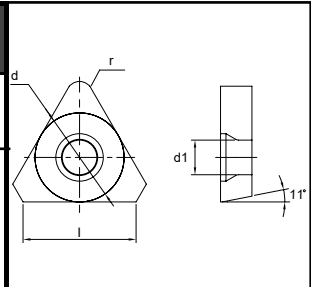
TPEX	Sipariş Kodu Order Code	l	l ₁	d	s	d ₁	r	α	
	TPEX 3307	33,00	23,35	19,05	7,00	6,6	—	11°	

TP□W	Sipariş Kodu Order Code	l	d	t	d ₁	r	
	TPEW33MM15S	26,7	18,953	7	6,7	1,6	
	TPEW33M726S	24	19,05	7	6,7	2,6	

SPIRAL BORU UÇLARI

SPIRAL PIPE INSERTS



Kod: 850x190x94.2x460KgxR/LxWS-4
Designation:

Ana Nokta: Kesme Şekli: 1 Tipi (Düz)
Main Point: Cutting Form: 1 Type (Straight)
Uç Dizaynı / Insert Designation: LNMN5000604
SNEN250604
Kartuş + Çivi Tipi / Locator + Wedge Type

Kesme Çapı / Cutter DIA: 850
Toplam Uç Sayısı / Total Number of Insert: 64pcs
Ağırlık / Weight: 460 Kg

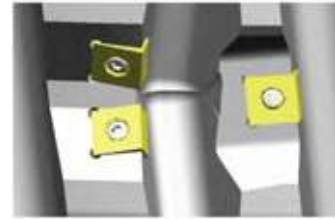

Kod: ECX600R/L-NS.AG3030.RF8.3H
Designation:

Ana Nokta: Kesme Şekli: X Tipi
Main Point: Cutting Form: X Type
Uç Dizaynı / Insert Designation: SNHQ150704S
Türdeki Vidalama / Screw on Type

Kesme Çapı / Cutter DIA: 600
Toplam Uç Sayısı / Total Number of Insert: 54pcs
Ağırlık / Weight: 137 Kg

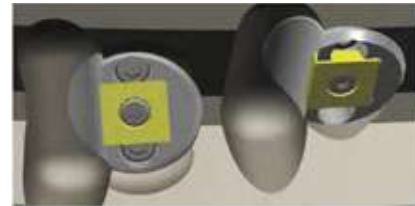

Kod: ECX443.6R/L-3232-BY
Designation:

Ana Nokta: Kesme Şekli: X Tipi
Main Point: Cutting Form: X Type
Uç Dizaynı / Insert Designation: SPEW190606-BY
Kartuş Tipi / Locator Type

Kesme Çapı / Cutter DIA: 443.6
Toplam Uç Sayısı / Total Number of Insert: 24pcs
Ağırlık / Weight: 80 Kg

SPIRAL BORU UÇLARI

SPIRAL PIPE INSERTS



Kod: ENF1000R/L-SAID01
Designation:

Ana Nokta: Kesme Şekli: 1 Tipi (Düz)
Main Point: Cutting Form: 1 Type (Straight)
Uç Dizayını / Insert Designation: LOCX3010Z
Kesici Türü / Locator Type

Kesme Çapı / Cutter DIA: 1000
Toplam Uç Sayısı / Total Number of Insert: 64pcs
Ağırlık / Weight: 530 Kg



Kod: ECX420R/L-3535-NS
Designation:

Ana Nokta: Kesme Şekli: X Tipi
Main Point: Cutting Form: X Type
Uç Dizayını / Insert Designation: SSNHQ150704S
Türdeki Vidalama / Screw on Type

Kesme Çapı / Cutter DIA: 420
Toplam Uç Sayısı / Total Number of Insert: 30pcs
Ağırlık / Weight: 65 Kg

SPIRAL BORU UÇLARI

SPIRAL PIPE INSERTS

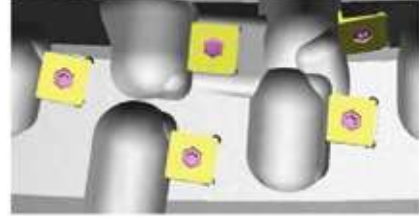
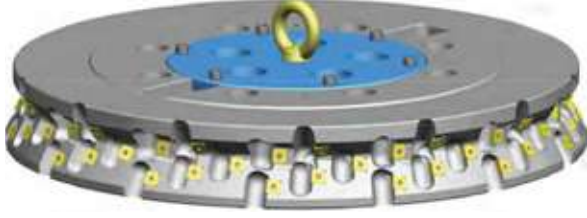

Kod: ECX640R/L-SK.AG3529.RF3
Designation:

Ana Nokta: Kesme Şekli: X Tipi
Main Point: Cutting Form: X Type
Uç Kodu / Insert Designation: SPEW150608S
Türdeki Vidalama / Screw on Type

Kesme Çapı / Cutter DIA: 640
Toplam Uç Sayısı / Total Number of Insert: 70pcs
Ağırlık / Weight: 207 Kg



Kod: ECF600R/L-T70
Designation:

Ana Nokta: Kesme Şekli: 1 Tipi
Main Point: Cutting Form: 1 Type
Uç Kodu / Insert Designation: LOCX3010-DT1
Kartuş Tipi / Locator Type

Kesme Çapı / Cutter DIA: 600
Toplam Uç Sayısı / Total Number of Insert: 56pcs
Ağırlık / Weight: 250 Kg

SPIRAL BORU UÇLARI

SPIRAL PIPE INSERTS



Kod: ECX600R/L-AG3825.RF4
Designation:

Ana Nokta: Kesme Şekli: X Tipi
Main Point: Cutting Form: X Type
Uç Kodu / Insert Designation: LOCX3010-DT1
Kartuş Tipi / Locator Type

Kesme Çapı / Cutter DIA: 600
Toplam Uç Sayısı / Total Number of Insert: 60pcs
Ağırlık / Weight: 300 Kg

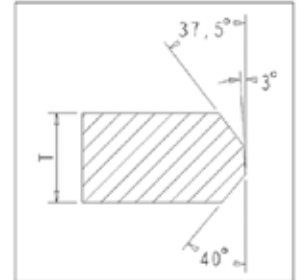

Kod: ECX600R/L-HRB.AG30225.RF4
Designation:

Ana Nokta: Kesme Şekli: X Tipi
Main Point: Cutting Form: X Type
Uç Kodu / Insert Designation: TPGW3306Z-1
Kartuş Tipi / Locator Type

Kesme Çapı / Cutter DIA: 600
Toplam Uç Sayısı / Total Number of Insert: 48pcs
Ağırlık / Weight: 220 Kg

SPİRAL BORU UÇLARI

SPİRAL PIPE INSERTS

Kaset Tip Kenar Frezeleme Kafası
Edge Milling Cutter with Cassette

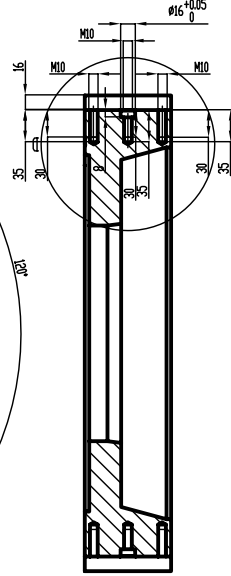
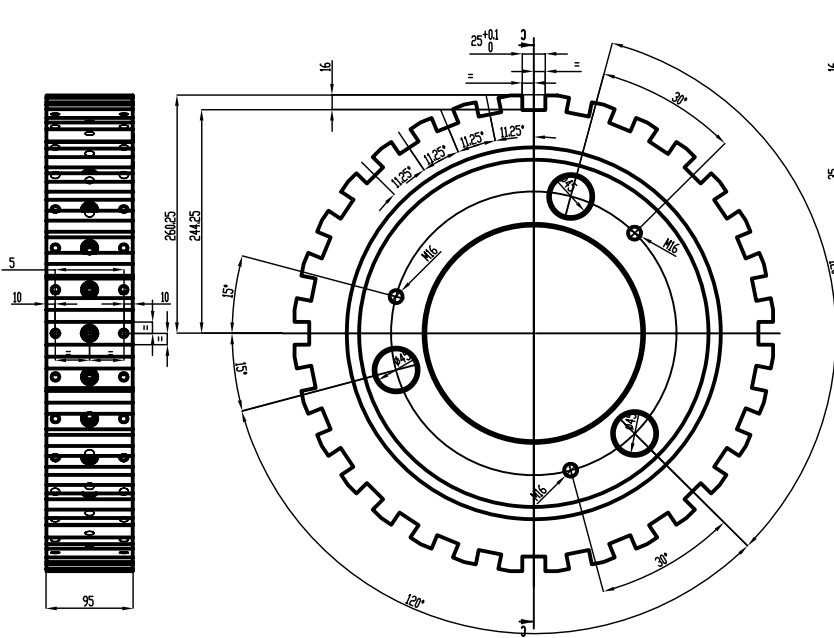
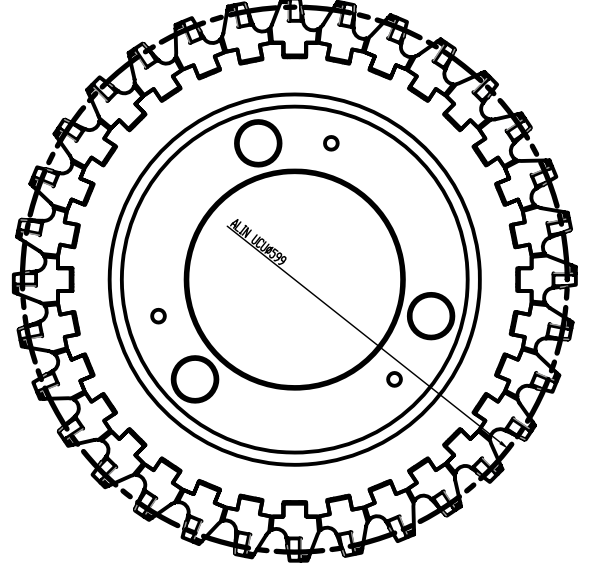
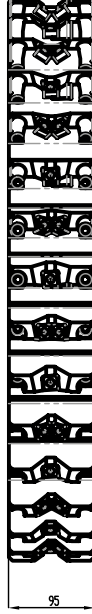
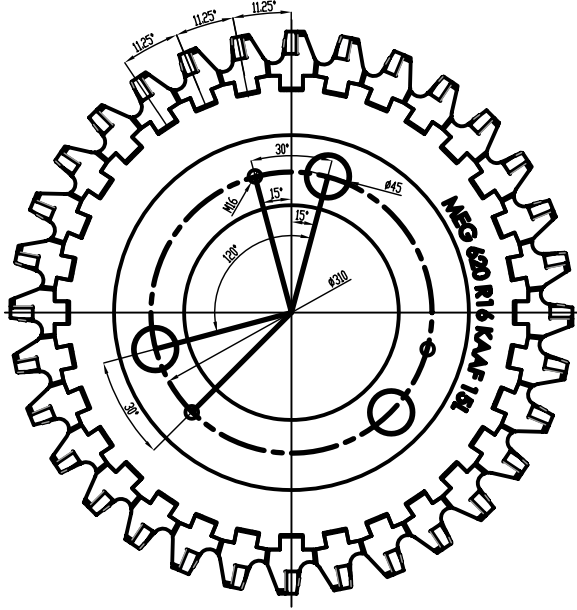

KESİT C-C

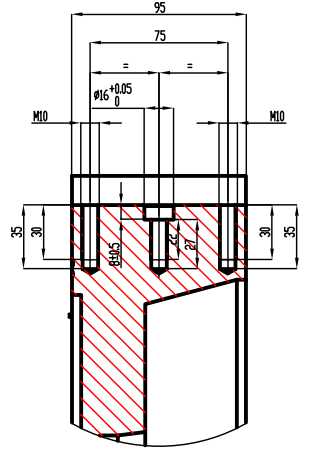

DETAY D
 BÜYÜKÇEK 1 : 2

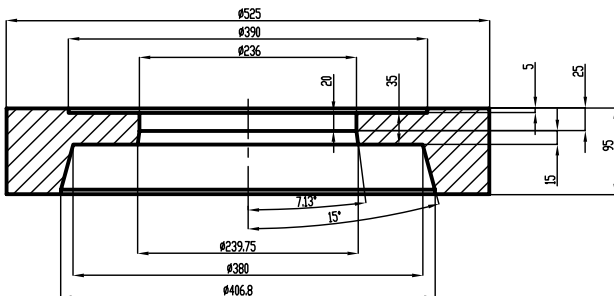



Gövde: MEG 620 R16 KAAF 15L

SPIRAL BORU UÇLARI

SPIRAL PIPE INSERTS

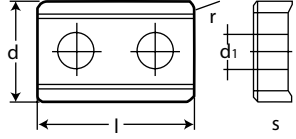
 Boru Kaynak Ağız Açma Uçları
Tube and Pipe End Beveling

LNUX	Sipariş Kodu Order Code	l	d	s	d1	r	
	LNUX 400924-BB0	40	25,4	9,52	9,2	2,4	

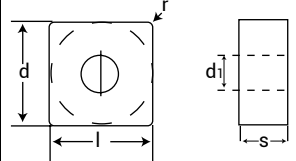
SNMM	Sipariş Kodu Order Code	l	d	s	d1	r	
	SNMM 250724-BBM	25,4	25,4	7,94	9,12	2,4	

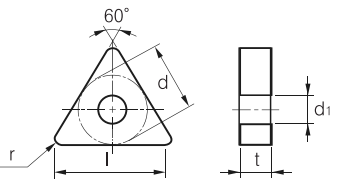
TNMG	Sipariş Kodu Order Code	l	l1	s	d1	r	
	TNMG 330724-ST	33	19,05	9,525	7,94	2,4	
	TNMG 330704-ST	33	19,05	9,525	7,94	0,4	

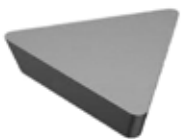
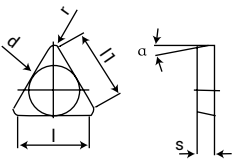
TPUN	Sipariş Kodu Order Code	l	l1	d	s	d1	r	a	
	TPUN 330620-T	33	26,07	19,5	6,35	-	2	11	

SPIRAL BORU UÇLARI

SPIRAL PIPE INSERTS

 Et Kalınlığı ve Pah Açısına Göre Uygun Takımın Seçilmesi
Choice of the appropriate tool in relation to wall
thickness and chamfer angle

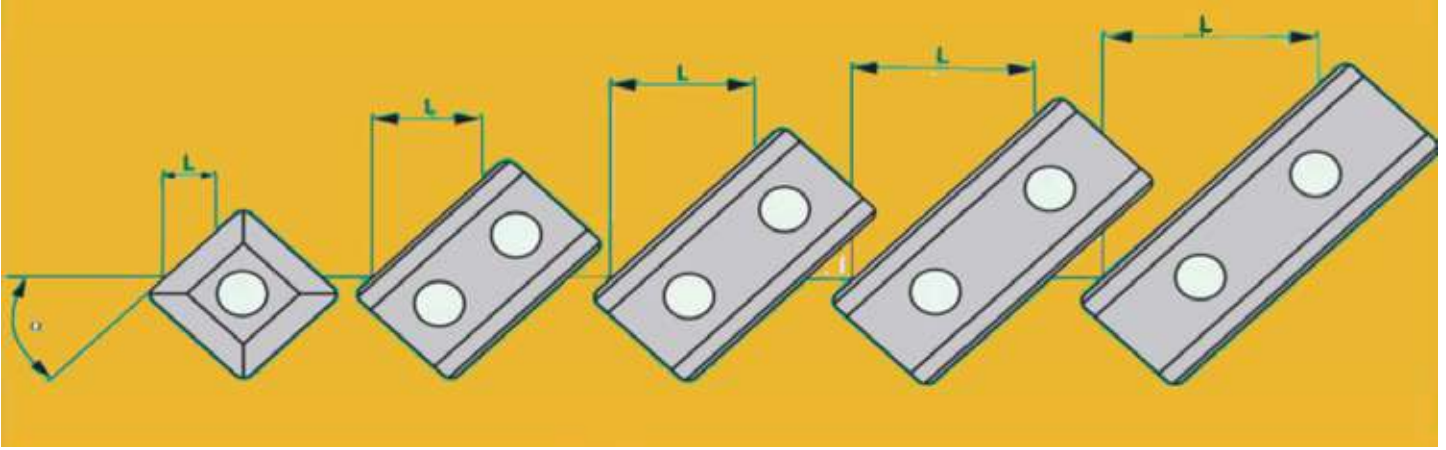

Kartuş / Cartridge	K-2 R/L	K-4 R/L	K-5 R/L	K-6 R/L	K-7 R/L
Takma Ucu / Indexable Insert	SNMM 25	LNUX 40	LNUX 50	LNUX 60	LNUX 70
Pah / Chamfer	L= max. L= Max. Et Kalınlığı / Max Wall Thickness				
$\alpha= 0^\circ$	16,0	32,0	40,0	50,0	60,0
$\alpha= 2^\circ$	16,0	32,0	40,0	50,0	60,0
$\alpha= 3^\circ$	16,0	32,0	40,0	50,0	60,0
$\alpha= 4^\circ$	16,0	32,0	40,0	49,5	60,0
$\alpha= 5^\circ$	15,5	32,0	40,0	49,5	59,5
$\alpha= 6^\circ$	15,5	32,0	40,0	49,5	59,5
$\alpha= 7^\circ$	15,5	32,0	39,5	49,5	59,5
$\alpha= 10^\circ$	15,5	31,5	39,5	49,0	59,5
$\alpha= 12,5^\circ$	15,5	31,0	39,0	48,5	58,5
$\alpha= 15^\circ$	15,5	31,0	38,5	48,0	58,0
$\alpha= 17,5^\circ$	15,0	30,5	38,0	47,5	57,0
$\alpha= 20^\circ$	15,0	30,0	37,5	46,5	56,0
$\alpha= 22^\circ$	15,0	29,5	37,0	46,0	55,0
$\alpha= 25^\circ$	14,5	29,0	36,0	45,0	54,0
$\alpha= 27^\circ$	14,0	28,5	35,5	44,0	53,0
$\alpha= 30^\circ$	14,0	27,5	34,5	43,0	51,0
$\alpha= 32^\circ$	13,5	27,0	34,0	42,0	50,0
$\alpha= 35^\circ$	13,0	26,0	32,5	40,5	48,0
$\alpha= 37^\circ$	12,5	25,5	32,0	39,5	47,0
$\alpha= 40^\circ$	12,0	24,5	30,5	37,5	45,0

SPİRAL BORU UÇLARI

SPİRAL PIPE INSERTS

 Kaynak Ağızı Açma Takımları
Beveling Tools

Kater: CS30NR 38.1 X 38.1 X 25

Uç: SNMM 2507

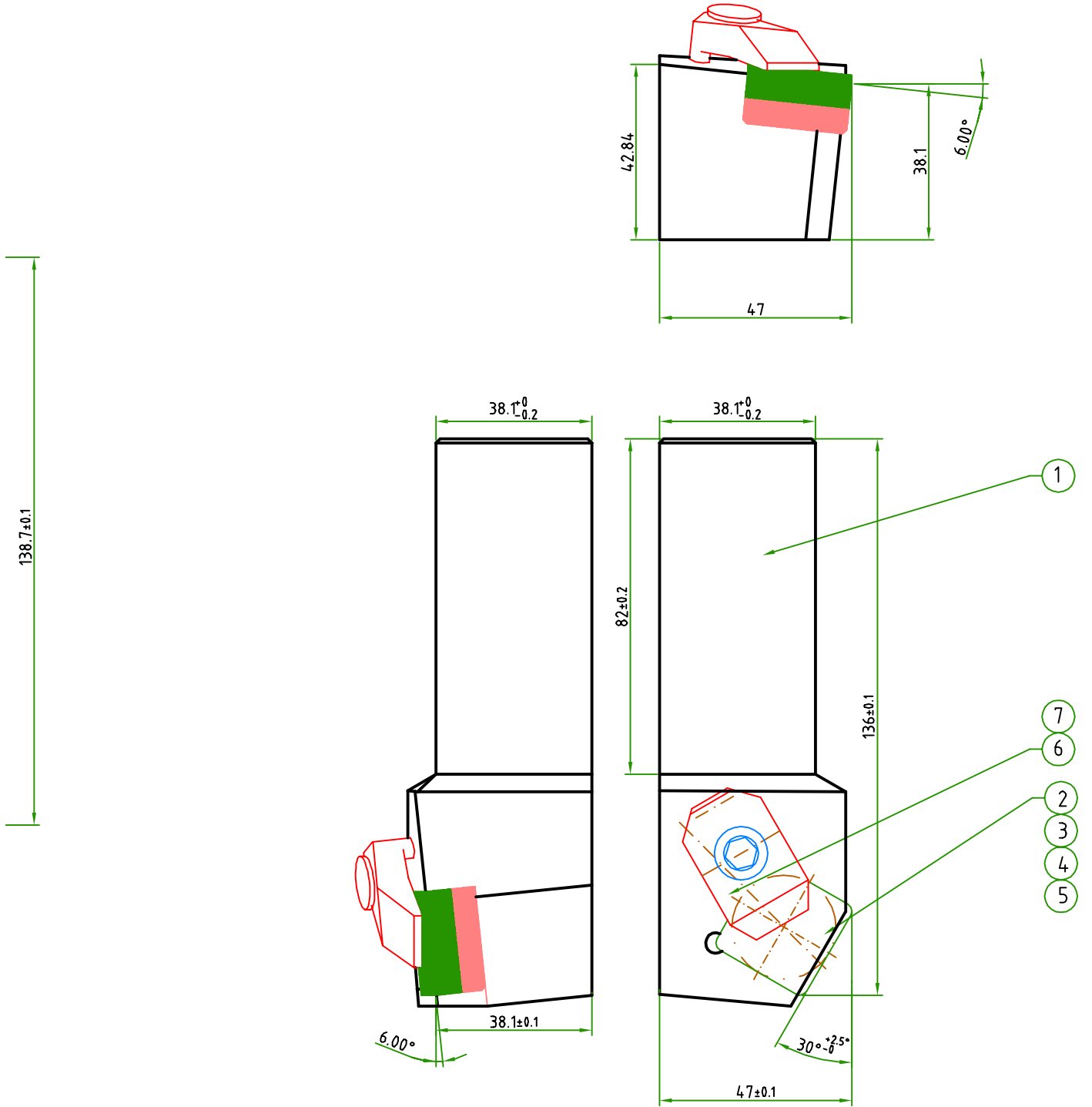

SPİRAL BORU UÇLARI

SPİRAL PIPE INSERTS

 Kaynak Ağızı Açma Takımları
Beveling Tools

Kater: CT30NL 40 40 X 33

Uç: TNMG 330704

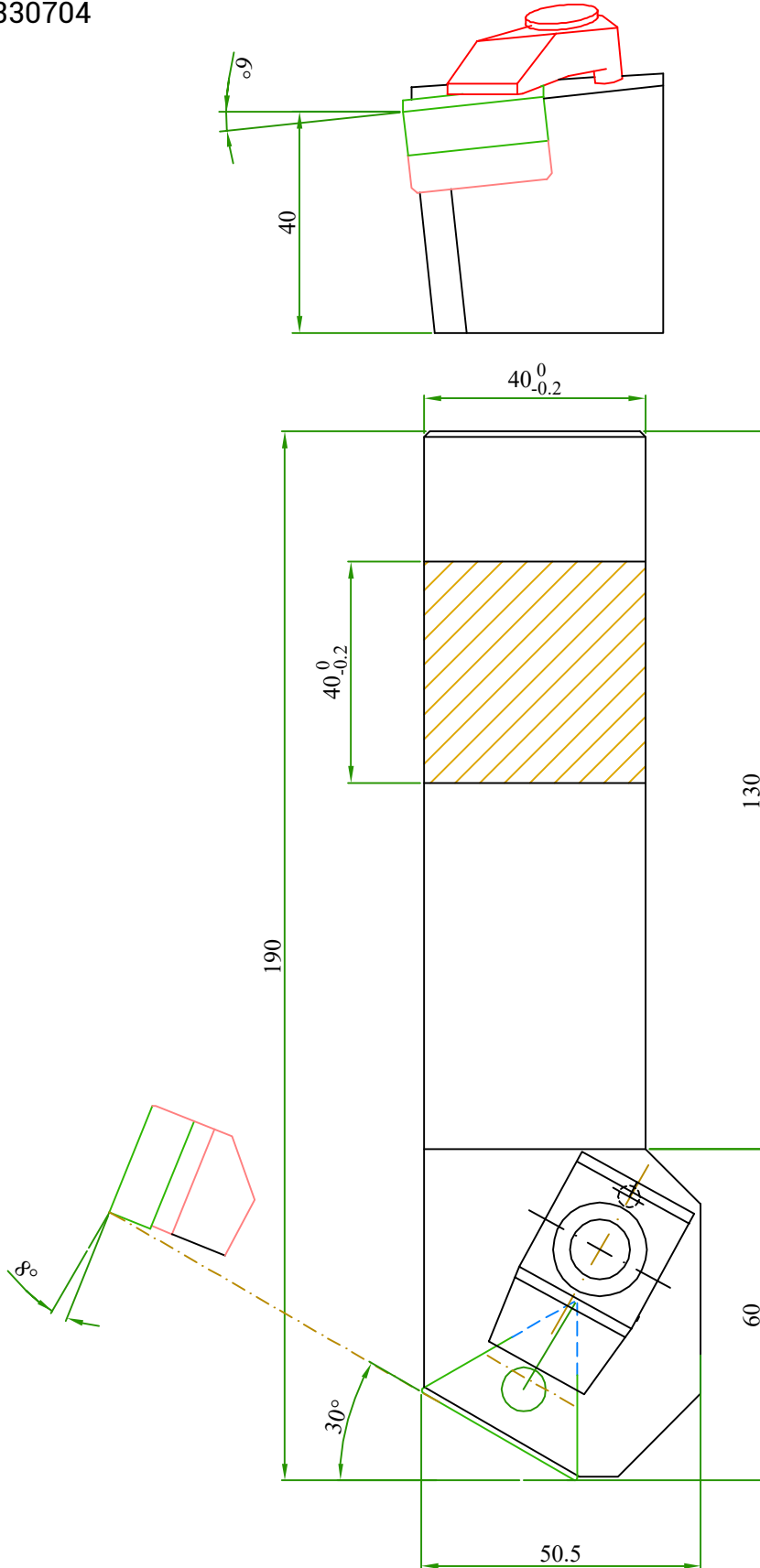

SPIRAL BORU UÇLARI

SPIRAL PIPE INSERTS

 Kaynak Ağız Açma Takımları
Beveling Tools

Kater: CT30NR 38.1 38.1 X 33 T04
Uç: TNMG 330704

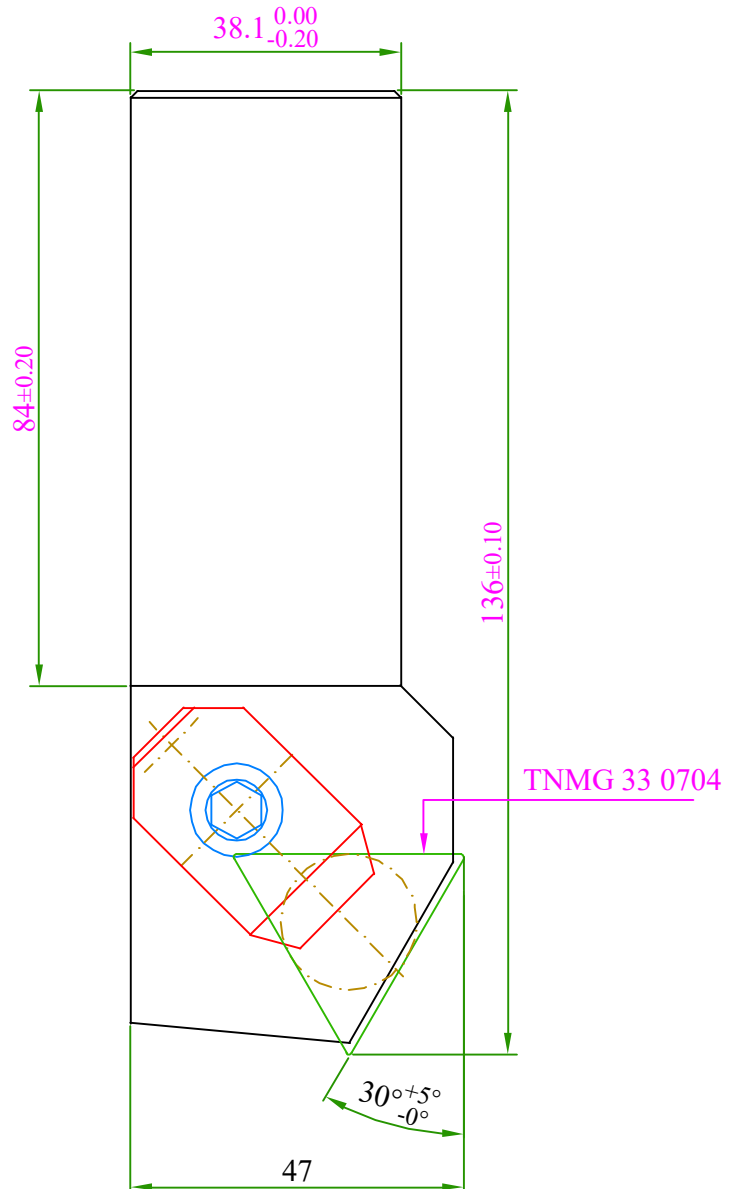
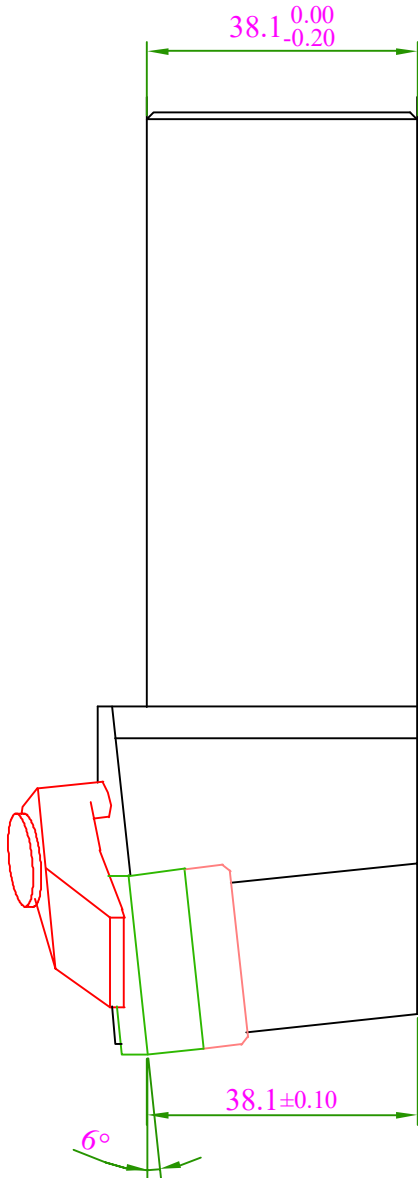
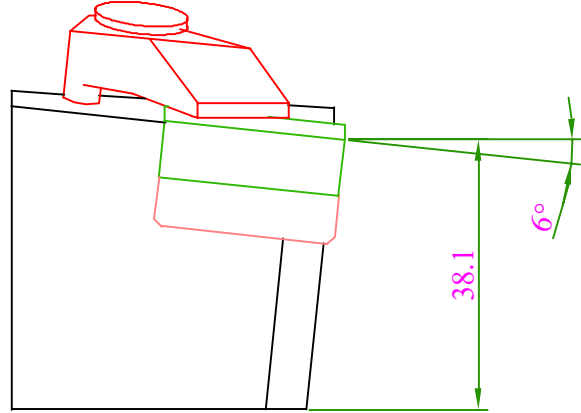

TORX UÇ SIKMA VİDASI

INSERT SCREW

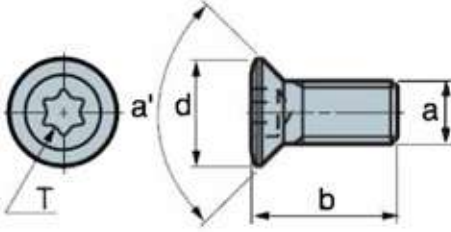

FTNA					
0307	M3X0,5	7.2	42.	9	60°
0406	M4X0.7	8.5	5.5	15	60°
0411	M4X0.7	11.0	5.5	15	60°
0415	M4X0.7	15.0	5.5	15	60°
0513	M5X0.8	13.0	7.0	20	60°
0516	M5X0.8	16.0	7.0	20	60°
0518	M5X1.0	17.2	8.8	20	60°



www.euroloy.com

**Head Office - Via Leonardo Da Vinci, 4
- 20054, Segrate
Milano MI ITALIA**

**Euroloy Italia (+39) 0282398309
Euroloy Turkey (+90) 850 933 3408**

✉ info@euroloy.com

📷 [@euroloytools](https://www.instagram.com/euroloytools)