

SOLID CARBIDE TOOLS

2026 | CATALOG

www.euroloy.com

 **EUROLOY**
CARBIDE TOOLS



TABLE OF

Contents

Carbide Endmill Coding System	L 4
Solid Carbide Endmills – Product & Application Overview	L 5
Solid Carbide Tools	L 7
Flat Carbide Endmill	L 10
Long Flat Carbide Endmill	L 11
Ball Nose Carbide Endmill	L 12
Ball Nose Long Carbide Endmill	L 13
Carbide Pirr Endmill	L 16
Corner Radius Carbide Endmill	L 18
Corner Radius Long Carbide Endmill	L 19
Carbide Aluminium Finishing Endmill	L 20
Long Carbide Aluminium Finishing Endmill	L 21
Carbide Aluminium Performance Endmill	L 22



Long Carbide Aluminium Performance Endmill L 23

Ball Nose Carbide Aluminium Endmill L 24

Ball Nose Long Carbide Aluminium Endmill L 25

Carbide Roughing Endmill L 27

Long Carbide Roughing Endmill L 28

Carbide Finishing Endmill Z6 L 29

Long Carbide Finishing Endmill Z6 L 30

Carbide Rounding Concave Cutter L 32

Carbide T-Slot Endmill L 33

3D Carbide Drill L 34

5D Carbide Drill L 38

Carbide Micro Drill L 42

Extra Long Carbide Drill L 43

CARBIDE ENDMILL CODING SYSTEM

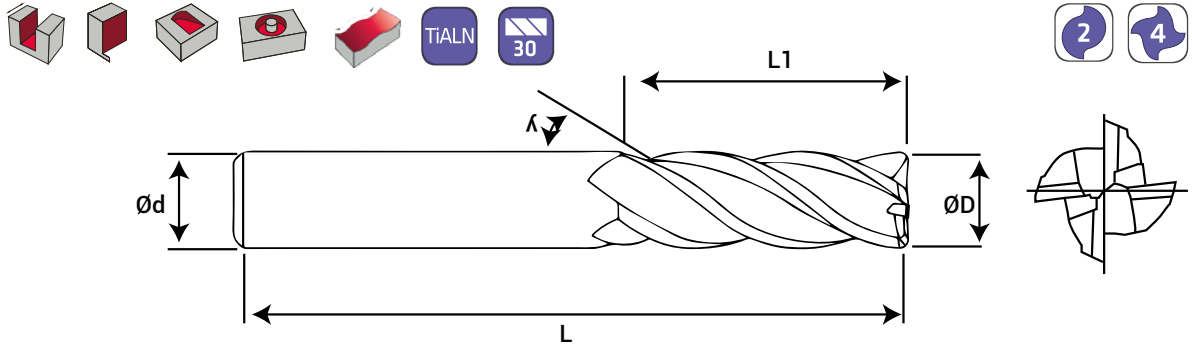
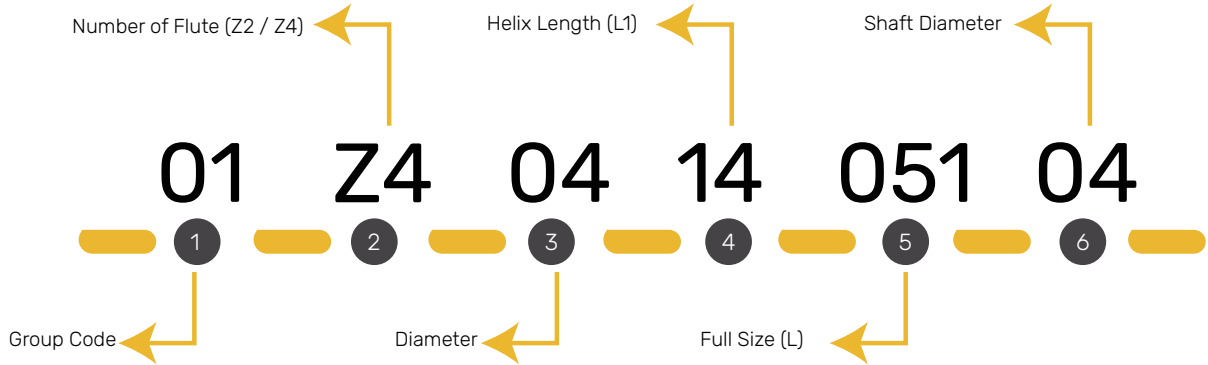

Group Code						
1	01	Z4	04	14	051	04
01 Flat Carbide Endmill (45HRC)	02 Long Flat Carbide Endmill (45HRC)	03 Ball Nose Carbide Endmill (45HRC & 60HRC)				
04 Ball Nose Long Carbide Endmill (45HRC & 60HRC)	05 Carbide Pirr Endmill (60HRC)	06 Corner Radius Carbide Endmill (55≤HRC)				
07 Corner Radius Long Carbide Endmill (55≤HRC)	08 Carbide Aluminium Finishing Endmill	09 Long Carbide Aluminium Finishing Endmill				
10 Carbide Aluminium Performance Endmill	11 Long Carbide Aluminium Performance Endmill	12 Ball Nose Carbide Aluminium Endmill				
13 Ball Nose Long Carbide Aluminium Endmill	14 Carbide Roughing Endmill	15 Long Roughing Endmill				
16 Carbide Finishing Endmill Z6	17 Long Carbide Finishing Endmill Z6	18 Carbide Rounding Concave Cutter				
19 Carbide T-Slot Endmill	20 3D Carbide Drill	21 5D Carbide Drill				
22 Carbide Micro Drill	23 Extra Long Carbide Drill					

Solid Carbide Tools







SOLID CARBIDE ENDMILLS – PRODUCT & APPLICATION OVERVIEW

Team No	Product	Carbide Rod Grade	Image	Page	Coating	Application Area	Number of Flute	Workpiece						
								P Steel	M Stainless Steel	K Cast Iron	N Non-ferrous Metal	S Heat Resistant Alloy	H Hardened Steel	
01	Flat Carbide Endmill	KH103S		10	●	General	4	★	○	★				
02	Long Flat Carbide Endmill	KH103S		11	●	General	4	★	○	★				
03	Ball Nose Carbide Endmill	KH103S		12	●	General	2-4	★	○	★				
04	Ball Nose Long Carbide Endmill	KH103S		13	●	General	2-4	★	○	★				
05	Carbide Pirr Endmill	KH103S		16	●	General	4	★	○	★	○	★		
06	Corner Radius Carbide Endmill	KH103S		18	●	High Speed	4	★		○		★	★	
07	Corner Radius Long Carbide Endmill	KH103S		19	●	High Speed	4	★		○		★	★	
08	Carbide Aluminium Finishing Endmill	KH100SR		20	○	Aluminum Finish	2-3				★			
09	Long Carbide Aluminium Finishing Endmill	KH100SR		21	○	Aluminum Finish	2-3				★			
10	Carbide Aluminium Performance Endmill	KH100SR		22	○	Aluminum Performance	3				★			
11	Long Carbide Aluminium Performance Endmill	KH100SR		23	○	Aluminum Performance	3				★			
12	Ball Nose Carbide Aluminium Endmill	KH100SR		24	○	Aluminum	2				★			
13	Ball Nose Long Carbide Aluminium Endmill	KH100SR		25	○	Aluminum	2				★			
14	Carbide Roughing Endmill	KH103S		27	●	General	4	★					○	
15	Long Carbide Roughing Endmill	KH103S		28	●	General	4	★					○	
16	Carbide Finishing Endmill Z6	KH103S		29	●	General	6	★	★				★	○

○ Coated
● Uncoated

★ Recommended
○ Secondary Option

SOLID CARBIDE ENDMILLS – PRODUCT & APPLICATION OVERVIEW

Team No	Product	Carbide Rod Grade	Image	Page	Coating	Application Area	Number of Flute	Workpiece					
								P	M	K	N	S	H
								Steel	Stainless Steel	Cast Iron	Non-ferrous Metal	Heat Resistant Alloy	Hardened Steel
17	Long Carbide Finishing Endmill Z6	KH103S		30	●	General	6	★	★			★	○
18	Carbide Rounding Concave Cutter	KH103S		32	●	General	4-6-8	★	○	★	○		
19	Carbide T-Slot Endmill	KH103S		33	●	General	-						
20	3D Carbide Drill	KH103S		34	●	General	-	★	○	★		○	
21	5D Carbide Drill	KH103S		38	●	General	-	★	○	★		○	
22	Carbide Micro Drill	KH103S		42	●	General	-	★	○	★		○	
23	Extra Long Carbide Drill	KH103S		43	●	General	-	★	○	★		○	

SOLID CARBIDE TOOLS

01

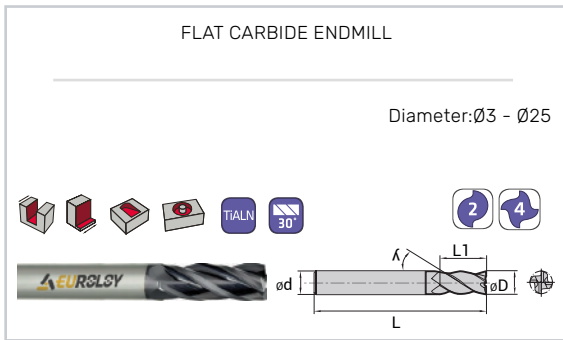

Page: 10

02

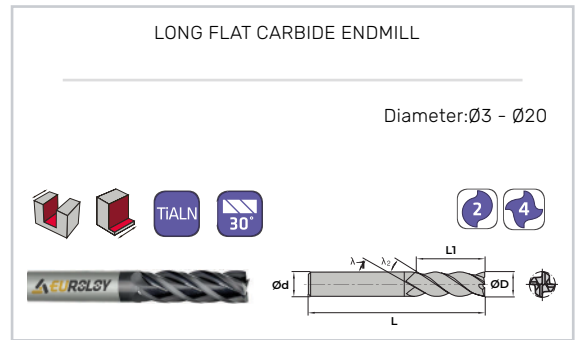

Page:11

03

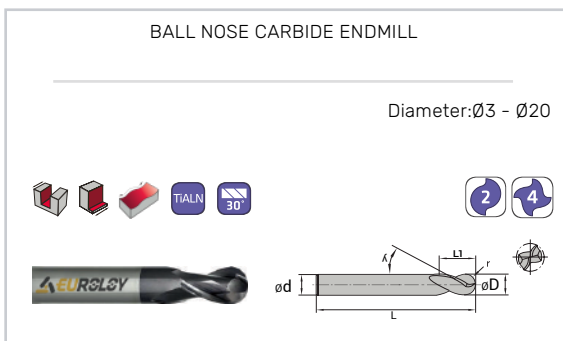

Page:12

04

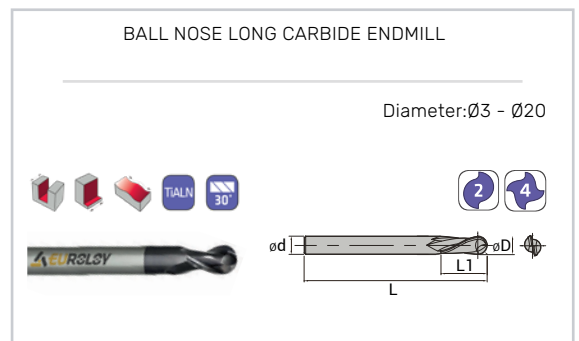

Page:13

05

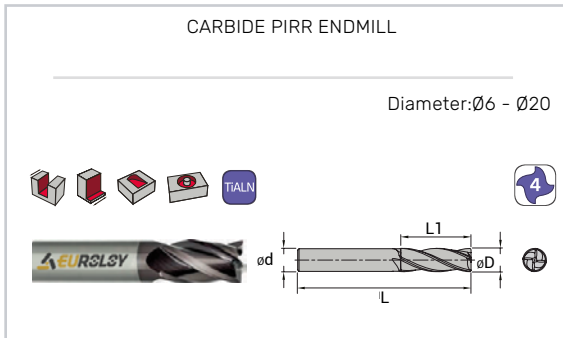

Page:16

06

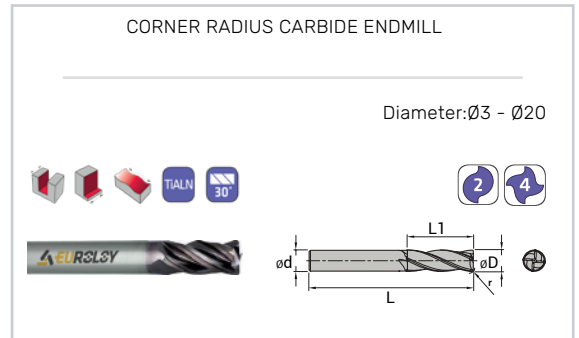

Page:18

07



Page: 19

08

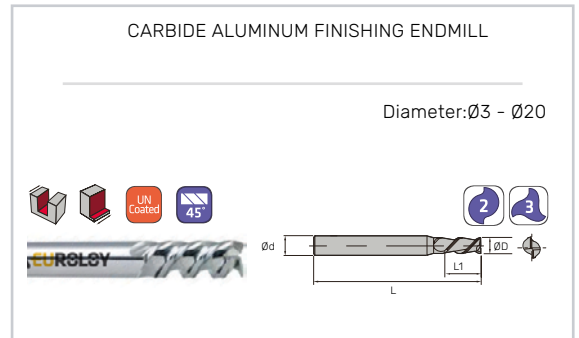

Page:20

SOLID CARBIDE TOOLS

09 LONG CARBIDE ALUMINIUM FINISHING ENDMILL

Diameter: $\varnothing 3 - \varnothing 20$

Page: 21

10 CARBIDE ALUMINIUM PERFORMANCE ENDMILL

Diameter: $\varnothing 3 - \varnothing 20$

Page:22

11 LONG C. ALUMINIUM PERFORMANCE ENDMILL

Diameter: $\varnothing 3 - \varnothing 20$

Page: 23

12 BALL NOSE CARBIDE ALUMINIUM ENDMILL

Diameter: $\varnothing 3 - \varnothing 20$

Page:24

13 LONG CARBIDE ROUGHING ENDMILL

Diameter: $\varnothing 6 - \varnothing 25$

Page: 25

14 CARBIDE ROUGHING ENDMILL

Diameter: $\varnothing 6 - \varnothing 28$

Page:27

15 LONG CARBIDE FINISHING ENDMILL Z6

Diameter: $\varnothing 6 - \varnothing 25$

Page: 28

16 CARBIDE FINISHING ENDMILL Z6

Diameter: $\varnothing 6 - \varnothing 28$

Page:29

17 LONG CARBIDE FINISHING ENDMILL Z6

Diameter: $\varnothing 6 - \varnothing 25$

Page: 30

18 CARBIDE ROUNDING CONCAVE CUTTER

Diameter: $\varnothing 8 - \varnothing 22$

Page:32

SOLID CARBIDE TOOLS

19 CARBIDE T-SLOT ENDMILL

Diameter: $\varnothing 6 - \varnothing 25$

TIALN 6 8 10

Technical drawing of a carbide T-slot endmill. The drawing shows a side view and an end view. The side view indicates the diameter is $\varnothing d$ and the length is L . The end view shows the T-shaped profile with a depth H . Above the drawing are icons for TIALN coating, 6, 8, and 10 flutes.

Page: 33

20 3D CARBIDE DRILL

Shaft Diameter: $\varnothing 3 - \varnothing 20$

TIALN 30°

Technical drawing of a 3D carbide drill. The drawing shows a side view and an end view. The side view indicates the diameter is $\varnothing d$ and the length is L . The end view shows the cutting edge angle of 30° . Above the drawing are icons for TIALN coating, a 30-degree angle, and a hand icon.

Page: 34

21 5D CARBIDE DRILL

Shaft Diameter: $\varnothing 6 - \varnothing 20$

TIALN 30°

Technical drawing of a 5D carbide drill. The drawing shows a side view and an end view. The side view indicates the diameter is $\varnothing d$ and the length is L . The end view shows the cutting edge angle of 30° . Above the drawing are icons for TIALN coating, a 30-degree angle, and a hand icon.

Page: 38

22 CARBIDE MICRO DRILL

Shaft Diameter: $\varnothing 3 - 6$

TIALN 30°

Technical drawing of a carbide micro drill. The drawing shows a side view and an end view. The side view indicates the diameter is $\varnothing d$ and the length is L . The end view shows the cutting edge angle of 30° and a length L_1 . Above the drawing are icons for TIALN coating, a 30-degree angle, and a hand icon.

Page: 42

23 EXTRA LONG CARBIDE DRILL

Shaft Diameter: $\varnothing 4 - 14$

TIALN 30°

Technical drawing of an extra long carbide drill. The drawing shows a side view and an end view. The side view indicates the diameter is $\varnothing d$ and the length is L . The end view shows the cutting edge angle of 30° and a length L_1 . Above the drawing are icons for TIALN coating, a 30-degree angle, and a hand icon.

Page: 43

01

FLAT CARBIDE ENDMILL

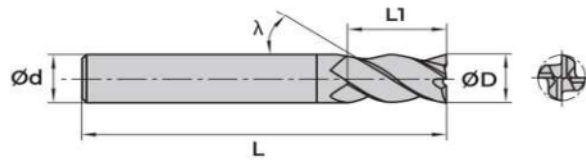

Order Code(Z:2)	Order Code(Z:4)	$\varnothing D$ (mm)	L_1 (mm)	L (mm)	$\varnothing d$ (mm)
01Z2031205003	01Z4031205003	3	12	50	3
01Z2041405104	01Z4041405104	4	14	51	4
01Z2051605105	01Z4051605105	5	16	51	5
01Z2061905806	01Z4061905806	6	19	58	6
01Z2072006407	01Z4072006407	7	20	64	7
01Z2082006408	01Z4082006408	8	20	64	8
01Z2092107309	01Z4092107309	9	21	73	9
01Z2102107310	01Z4102107310	10	21	73	10
01Z2112508411	01Z4112508411	11	25	84	11
01Z2122508412	01Z4122508412	12	25	84	12
01Z2133208413	01Z4133208413	13	32	84	13
01Z2143208414	01Z4143208414	14	32	84	14
01Z2153209315	01Z4153209315	15	32	93	15
01Z2163209316	01Z4163209316	16	32	93	16
01Z2183509318	01Z4183509318	18	35	93	18
01Z2203810020	01Z4203810020	20	38	100	20
01Z2223810022	01Z4223810022	22	38	100	22
01Z2243810024	01Z4243810024	24	38	100	24
01Z2253810025	01Z4253810025	25	38	100	25

02

LONG FLAT CARBIDE ENDMILL

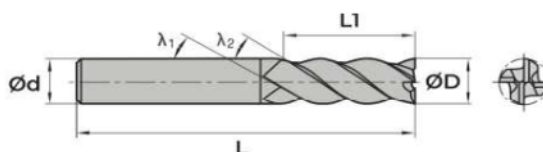

Order Code(Z:2)	Order Code(Z:4)	$\varnothing D$ (mm)	L_1 (mm)	L (mm)	$\varnothing d$ (mm)
02Z2032007503	02Z4032007503	3	20	75	3
02Z2042007504	02Z4042007504	4	20	75	4
02Z2052507505	02Z4052507505	5	25	75	5
02Z2063007506	02Z4063007506	6	30	75	6
02Z2083007508	02Z4083007508	8	30	75	8
02Z2032010003	02Z4032010003	3	20	100	3
02Z2042010004	02Z4042010004	4	20	100	4
02Z2052510005	02Z4052510005	5	25	100	5
02Z2064010006	02Z4064010006	6	40	100	6
02Z2084510008	02Z4084510008	8	45	100	8
02Z2104510010	02Z4104510010	10	45	100	10
02Z2124510012	02Z4124510012	12	45	100	12
02Z2144510014	02Z4144510014	14	45	100	14
02Z2164510016	02Z4164510016	16	45	100	16
02Z2184510018	02Z4184510018	18	45	100	18
02Z2204510020	02Z4204510020	20	45	100	20
02Z2086515008	02Z4086515008	8	65	150	8
02Z2106515010	02Z4106515010	10	65	150	10
02Z2126515012	02Z4126515012	12	65	150	12
02Z2146515014	02Z4146515014	14	65	150	14
02Z2167515016	02Z4167515016	16	75	150	16
02Z2187515018	02Z4187515018	18	75	150	18
02Z2207515020	02Z4207515020	20	75	150	20
02Z2227515022	02Z4227515022	22	75	150	22
02Z2247515024	02Z4247515024	24	75	150	24
02Z2257515025	02Z4257515025	25	75	150	25

03

BALL NOSE CARBIDE ENDMILL

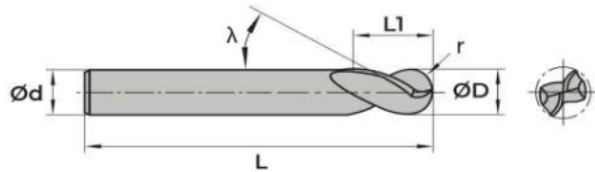

Order Code(Z:2)	Order Code(Z:4)	$\varnothing D$ (mm)	L_1 (mm)	L(mm)	$\varnothing d$ (mm)
03Z2031205003A	03Z4031205003A	3	12	50	3
03Z2041405104A	03Z4041405104A	4	14	51	4
03Z2051605105A	03Z4051605105A	5	16	51	5
03Z2061905806A	03Z4061905806A	6	19	58	6
03Z2072006407A	03Z4072006407A	7	20	64	7
03Z2082006408A	03Z4082006408A	8	20	64	8
03Z2092107309A	03Z4092107309A	9	21	73	9
03Z2102107310A	03Z4102107310A	10	21	73	10
03Z2112508411A	03Z4112508411A	11	25	84	11
03Z2122508412A	03Z4122058412A	12	25	84	12
03Z2132508413A	03Z4132508413A	13	32	84	13
03Z2143208414A	03Z4143208414A	14	32	84	14
03Z2163209316A	03Z4163209316A	16	32	93	16
03Z2183509318A	03Z4183509318A	18	35	93	18
03Z2203810020A	03Z4203810020A	20	38	100	20
03Z2203810022A	03Z4203810022A	22	38	100	22
03Z2403810024A	03Z4403810024A	24	38	100	24
03Z2253810025A	03Z4253810025A	25	38	100	25

04

BALL NOSE LONG CARBIDE ENDMILL

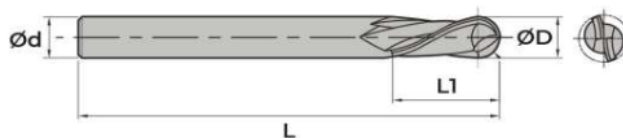

Order Code(Z:2)	Order Code (Z:4)	$\varnothing D$ (mm)	L_1 (mm)	L(mm)	$\varnothing d$ (mm)
04Z2032007503A	04Z4032007503A	3	20	75	3
04Z2042007504A	04Z4042007504A	4	20	75	4
04Z2052007505A	04Z4052007505A	5	25	75	5
04Z2063007506A	04Z4063007506A	6	30	75	6
04Z2083007508A	04Z4083007508A	8	30	75	8
04Z2032010003A	04Z4032010003A	3	20	100	3
04Z2042010004A	04Z4042010004A	4	20	100	4
04Z2052510005A	04Z4052510005A	5	25	100	5
04Z2064010006A	04Z4064010006A	6	40	100	6
04Z2084510008A	04Z4084510008A	8	45	100	8
04Z2104510010A	04Z4104510010A	10	45	100	10
04Z2124510012A	04Z4124510012A	12	45	100	12
04Z2144510014A	04Z4144510014A	14	45	100	14
04Z2164510016A	04Z4164510016A	16	45	100	16
04Z2184510018A	04Z4184510018A	18	45	100	18
04Z2204510020A	04Z4204510020A	20	45	100	20
04Z2086515008A	04Z4086515008A	8	65	150	8
04Z2106515010A	04Z4106515010A	10	65	150	10
04Z2126515012A	04Z4126515012A	12	65	150	12
04Z2146515014A	04Z4146515014A	14	65	150	14
04Z2167515016A	04Z4167515016A	16	75	150	16
04Z2187515018A	04Z4187515018A	18	75	150	18
04Z2207515020A	04Z4207515020A	20	75	150	20
04Z2227515022A	04Z4227515022A	22	75	150	22
04Z2247515024A	04Z4247515024A	24	75	150	24
04Z2257515025A	04Z4257515025A	25	75	150	25

APPLICATIONS

			$ae = 1.0 \times \varnothing$ $ap(\text{mm}) = 0.5 \times \varnothing$		$ae = 0.5 \times \varnothing$ $ap(\text{mm}) = 1.0 \times \varnothing$		$ae = 0.1 \times \varnothing$ $ap(\text{mm}) = 1.5 \times \varnothing$	
ISO	Material	HB	fz (mm)	Vc m/min	fz (mm)	Vc m/min	fz (mm)	Vc m/min
P	Unalloyed steel	190	F0,1	145	F0,4	175	F0,6	290
	Low-alloyed steel	240	F0,1	110	F0,4	135	F0,6	230
	High alloyed steel	380	F0,2	80	F0,5	100	F0,6	200
	Ferritic/martensitic stainless steel	200	F0,2	80	F0,5	90	F0,4	150
M	Austenitic stainless steel	200	F0,1	70	F0,4	80	F0,6	120
	Duplex (austenitic/ferritic) stainless steel	260	F0,2	60	F0,5	70	F0,4	90
K	Malleable cast iron	200	F0,1	150	F0,4	180	F0,6	250
	Gray cast iron	180	F0,1	150	F0,4	180	F0,6	250
	Nodular cast iron	215	F0,1	160	F0,4	190	F0,6	270
N	Aluminium based alloys	100	F0,3	680	F0,3	835	F0,9	950
	Aluminium based alloys	75	F0,3	230	F0,3	305	F0,9	410
	Aluminium based alloys	130	F0,3	100	F0,3	130	F0,9	195
	Copper and copper alloys	90	F0,3	130	F0,3	170	F0,9	245
S	Iron based superalloys	350	F0,2	25	F0,5	30	F0,7	40
	Nickel based super alloys	320	F0,2	40	F0,5	50	F0,7	70

APPLICATIONS

Feed per Tooth Chart

∅	2	3	4	6	8	10	12	14	16	20	25
fz(mm)	0.079	0.118	0.157	0.236	0.315	0.394	0.472	0.551	0.630	0.787	0.984
F0,1	0.012	0.016	0.021	0.029	0.037	0.046	0.054	0.062	0.071	0.087	0.108
	0.0005	0.0006	0.0008	0.0011	0.0015	0.0018	0.0021	0.0025	0.0028	0.0034	0.0043
F0,2	0.011	0.015	0.018	0.025	0.032	0.038	0.045	0.052	0.058	0.072	0.089
	0.0004	0.0006	0.0007	0.0010	0.0012	0.0015	0.0018	0.0020	0.0023	0.0028	0.0035
F0,3	0.027	0.033	0.040	0.053	0.066	0.079	0.092	0.105	0.118	0.145	0.177
	0.0010	0.0013	0.0016	0.0021	0.0026	0.0031	0.0036	0.0041	0.0047	0.0057	0.0070
F0,4	0.025	0.029	0.034	0.044	0.053	0.062	0.072	0.081	0.091	0.110	0.133
	0.0010	0.0012	0.0013	0.0017	0.0021	0.0025	0.0028	0.0032	0.0036	0.0043	0.0052
F0,5	0.023	0.027	0.030	0.037	0.044	0.051	0.058	0.065	0.072	0.086	0.104
	0.0009	0.0011	0.0012	0.0015	0.0017	0.0020	0.0023	0.0026	0.0028	0.0034	0.0041
F0,6	0.028	0.035	0.041	0.054	0.067	0.080	0.093	0.106	0.119	0.145	0.177
	0.0011	0.0014	0.0016	0.0021	0.0027	0.0032	0.0037	0.0042	0.0047	0.0057	0.0070
F0,7	0.025	0.031	0.036	0.047	0.057	0.068	0.079	0.089	0.100	0.121	0.148
	0.0010	0.0012	0.0014	0.0018	0.0023	0.0027	0.0031	0.0035	0.0039	0.0048	0.0058
F0,8	0.038	0.046	0.053	0.069	0.085	0.100	0.116	0.131	0.147	0.178	0.217
	0.0015	0.0018	0.0021	0.0027	0.0033	0.0039	0.0046	0.0052	0.0058	0.0070	0.0085

05

CARBIDE PIRR ENDMILL

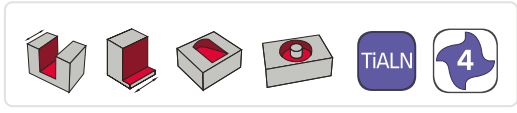
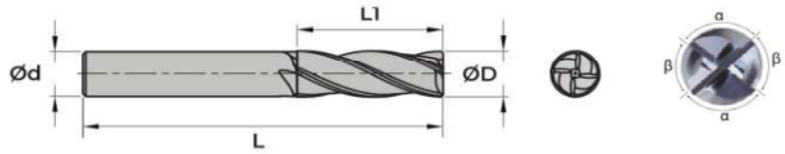

Order Code (Z:4)	ØD(mm)	L1(mm)	L(mm)	Ød(mm)
05Z4030905806	3	9	58	6
05Z4041105806	4	11	58	6
05Z4051405806	5	14	58	6
05Z4061905806	6	19	58	6
05Z4072006407	7	20	64	7
05Z4082006408	8	20	64	8
05Z4092107309	9	21	73	9
05Z4102107310	10	21	73	10
05Z4112508411	11	25	84	11
05Z4122508412	12	25	84	12
05Z4133208413	13	32	84	13
05Z4143208414	14	32	84	14
05Z4153209315	15	32	93	15
05Z4163209316	16	32	93	16
05Z4183509318	18	35	93	18
05Z4203810020	20	38	100	20

APPLICATIONS

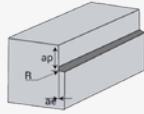
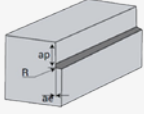
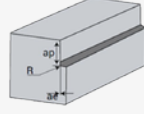
											
			PIRR ENDMILL ap(mm) = 3.0 x Ø			PIRR ENDMILL ap(mm) = 3.0 x Ø			PIRR ENDMILL ap(mm) = 3.5 x Ø		
ISO	Material	HB	ae	fz (mm)	Vc m/min	ae	fz (mm)	Vc m/min	ae	fz (mm)	Vc m/min
P	Unalloyed steel	190	0.15 x Ø	F0,1	250	0.10 x Ø	F0,1	275	0.07 x Ø	F0,4	303
	Low-alloyed steel	240	0.15 x Ø	F0,1	240	0.10 x Ø	F0,2	264	0.07 x Ø	F0,4	290
	High alloyed steel	320	0.15 x Ø	F0,2	140	0.10 x Ø	F0,2	154	0.07 x Ø	F0,5	169
	Ferritic/martensitic stainless steel	200	0.15 x Ø	F0,2	120	0.10 x Ø	F0,2	132	0.07 x Ø	F0,5	145
M	Austenitic stainless steel	200	0.15 x Ø	F0,2	150	0.10 x Ø	F0,2	165	0.07 x Ø	F0,5	182
	Duplex (austenitic/ferritic) stainless steel	260	0.15 x Ø	F0,2	130	0.10 x Ø	F0,2	143	0.07 x Ø	F0,5	157
K	Malleable cast iron	200	0.15 x Ø	F0,1	235	0.10 x Ø	F0,1	259	0.07 x Ø	F0,4	284
	Gray cast iron	180	0.15 x Ø	F0,1	240	0.10 x Ø	F0,1	264	0.07 x Ø	F0,4	290
	Nodular cast iron	215	0.15 x Ø	F0,1	245	0.10 x Ø	F0,1	270	0.07 x Ø	F0,4	296
N	Aluminium based alloys	100	0.15 x Ø	F0,4	950	0.10 x Ø	F0,4	1140	0.07 x Ø	F0,6	1140
	Aluminium based alloys	75	0.15 x Ø	F0,4	410	0.10 x Ø	F0,4	492	0.07 x Ø	F0,6	492
	Aluminium based alloys	130	0.15 x Ø	F0,4	195	0.10 x Ø	F0,4	234	0.07 x Ø	F0,6	234
S	Copper and copper alloys	90	0.15 x Ø	F0,4	245	0.10 x Ø	F0,4	294	0.07 x Ø	F0,6	294
	Nickel based superalloys	350	0.05 x Ø	F0,3	55	0.05 x Ø	F0,3	55	0.05 x Ø	F0,3	55
	Titanium based alloys	320	0.05 x Ø	F0,3	120	0.05 x Ø	F0,3	120	0.05 x Ø	F0,3	120

06

CORNER RADIUS CARBIDE ENDMILL

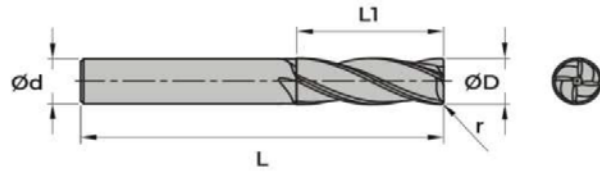

Order Code (Z:2)	Order Code (Z:4)	Ø D(mm)	L1(mm)	L(mm)	Ø d(mm)
06Z2031205003R#	06Z4031205003R#	3	12	50	3
06Z2041405104R#	06Z4041405104R#	4	14	51	4
06Z2051605105R#	06Z4051605105R#	5	16	51	5
06Z2061905806R#	06Z4061905806R#	6	19	58	6
06Z2072006407R#	06Z4072006407R#	7	20	64	7
06Z2082006408R#	06Z4082006408R#	8	20	64	8
06Z2092107309R#	06Z4092107309R#	9	21	73	9
06Z2102107310R#	06Z4102107310R#	10	21	73	10
06Z2112508411R#	06Z4112508411R#	11	25	84	11
06Z2122508412R#	06Z4122508412R#	12	25	84	12
06Z2133208413R#	06Z4133208413R#	13	32	84	13
06Z2143208414R#	06Z4143208414R#	14	32	84	14
06Z2153209315R#	06Z4153209315R#	15	32	93	15
06Z2163209316R#	06Z4163209316R#	16	32	93	16
06Z2183509318R#	06Z4183509318R#	18	35	93	18
06Z2203810020R#	06Z4203810020R#	20	38	100	20
06Z2223810022R#	06Z4223810022R#	22	38	100	22
06Z2243810024R#	06Z4243810024R#	24	38	100	24
06Z2253810025R#	06Z4253810025R#	25	38	100	25

07

CORNER RADIUS LONG CARBIDE ENDMILL

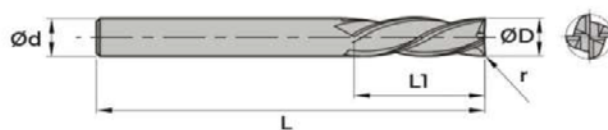

Order Code (Z:2)	Order Code (Z:4)	ØD(mm)	L1(mm)	L(mm)	Ød(mm)
07Z2032007503R#	07Z4032007503R#	3	20	75	3
07Z2042007504R#	07Z4042007504R#	4	20	75	4
07Z2052507506R#	07Z4052507506R#	5	25	75	5
07Z2063007506R#	07Z4063007506R#	6	30	75	6
07Z2083007508R#	07Z4083007508R#	8	30	75	8
07Z2032010003R#	07Z4032010003R#	3	20	100	3
07Z2042010004R#	07Z4042010004R#	4	20	100	4
07Z2052510005R#	07Z4052510005R#	5	25	100	5
07Z2064010006R#	07Z4064010006R#	6	40	100	6
07Z2084510008R#	07Z4084510008R#	8	45	100	8
07Z2104510010R#	07Z4104510010R#	10	45	100	10
07Z2124510012R#	07Z4124510012R#	12	45	100	12
07Z2144510014R#	07Z4144510014R#	14	45	100	14
07Z2164510016R#	07Z4164510016R#	16	45	100	16
07Z2184510018R#	07Z4184510018R#	18	45	100	18
07Z2204510020R#	07Z4204510020R#	20	45	100	20
07Z2086515008R#	07Z4086515008R#	8	65	150	8
07Z2106515010R#	07Z4106515010R#	10	65	150	10
07Z2126515012R#	07Z4126515012R#	12	65	150	12
07Z2146515014R#	07Z4146515014R#	14	65	150	14
07Z2167515016R#	07Z4167515016R#	16	75	150	16
07Z2187515018R#	07Z4187515018R#	18	75	150	18
07Z2207515020R#	07Z4207515020R#	20	75	150	20
07Z2227515022R#	07Z4227515022R#	22	75	150	22
07Z2247515024R#	07Z4247515024R#	24	75	150	24
07Z2257515025R#	07Z4257515025R#	25	75	150	25

08

CARBIDE ALUMINIUM FINISHING ENDMILL

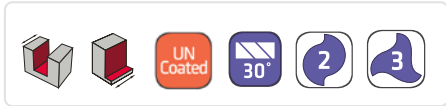
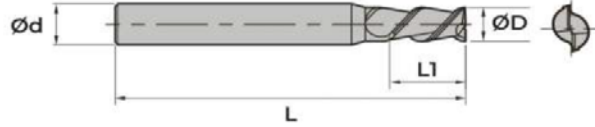

Order Code (Z:2)	Order Code (Z:4)	Ø D(mm)	L1(mm)	L(mm)	Ø d(mm)
08Z2031205003	08Z4031205003	3	12	50	3
08Z2041405105	08Z4041405105	4	14	51	4
08Z2051605105	08Z4051605105	5	16	51	5
08Z2061905806	08Z4061905806	6	19	58	6
08Z2072006007	08Z4072006007	7	20	60	7
08Z2082006408	08Z4082006408	8	20	64	8
08Z2092106709	08Z4092106709	9	21	67	9
08Z2102107310	08Z4102107310	10	21	73	10
08Z2112507512	08Z4112507512	11	25	75	11
08Z2122508412	08Z4122508412	12	25	84	12
08Z2133208413	08Z4133208413	13	32	84	13
08Z2143208414	08Z4143208414	14	32	84	14
08Z2153209315	08Z4153209315	15	32	93	15
08Z2163209316	08Z4163209316	16	32	93	16
08Z2183509318	08Z4183509318	18	35	93	18
08Z2203810020	08Z4203810020	20	38	100	20

09

LONG CARBIDE ALUMINIUM FINISHING ENDMILL

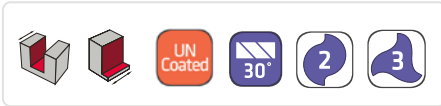
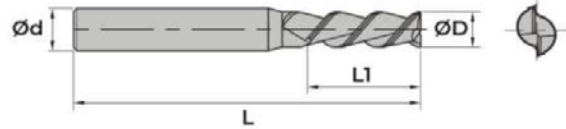

Order Code (Z:2)	Order Code (Z:3)	ØD(mm)	L1(mm)	L(mm)	Ød(mm)
09Z2032007503	09Z3032007503	3	20	75	3
09Z2042007504	09Z3042007504	4	20	75	4
09Z2052507505	09Z3052507505	5	25	75	5
09Z2063007506	09Z3063007506	6	30	75	6
09Z2083007508	09Z3083007508	8	30	75	8
09Z2032010003	09Z3032010003	3	20	100	3
09Z2042010004	09Z3042010004	4	20	100	4
09Z2052510005	09Z3052510005	5	25	100	5
09Z2063010006	09Z3063010006	6	30	100	6
09Z2083010008	09Z3083010008	8	30	100	8
09Z2104510010	09Z3104510010	10	45	100	10
09Z2124510012	09Z3124510012	12	45	100	12
09Z2144510014	09Z3144510014	14	45	100	14
09Z2164510016	09Z3164510016	16	45	100	16
09Z2184510018	09Z3184510018	18	45	100	18
09Z2204510020	09Z3204510020	20	45	100	20
09Z2086515008	09Z3086515008	8	65	150	8
09Z2106515010	09Z3106515010	10	65	150	10
09Z2126515012	09Z3126515012	12	65	150	12
09Z2146515014	09Z3146515014	14	65	150	14
09Z2167515016	09Z3167515016	16	75	150	16
09Z2187515018	09Z3187515018	18	75	150	18
09Z2207515020	09Z3207515020	20	75	150	20

10

CARBIDE ALUMINIUM PERFORMANCE ENDMILL

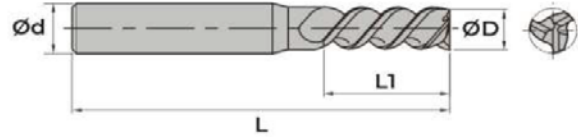

Order Code(Z:3)	ØD(mm)	L1(mm)	L(mm)	Ø d(mm)
10Z3031205003	3	12	50	3
10Z3041405104	4	14	51	4
10Z3051605105	5	16	51	5
10Z3061905806	6	19	58	6
10Z3072006407	7	20	64	7
10Z3082006408	8	20	64	8
10Z3092107309	9	21	73	9
10Z3102107310	10	21	73	10
10Z3112508411	11	25	84	11
10Z3122508412	12	25	84	12
10Z3133208413	13	32	84	13
10Z3143208414	14	32	84	14
10Z3153209315	15	32	93	15
10Z3163209316	16	32	93	16
10Z3183509318	18	35	93	18
10Z3203810020	20	38	100	20

11

LONG CARBIDE ALUMINIUM PERFORMANCE ENDMILL

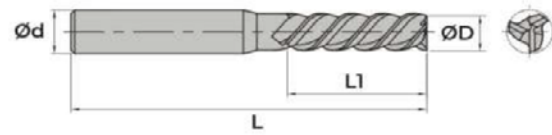

Order Code(Z:3)	ØD(mm)	L1(mm)	L(mm)	Ød(mm)
11Z3032007503	3	20	75	3
11Z3042007504	4	20	75	4
11Z3052507505	5	25	75	5
11Z3063007506	6	30	75	6
11Z3083007508	8	30	75	8
11Z3032010003	3	20	100	3
11Z3042010004	4	20	100	4
11Z3052510005	5	25	100	5
11Z3063010006	6	30	100	6
11Z3083010008	8	30	100	8
11Z3104510010	10	45	100	10
11Z3124510012	12	45	100	12
11Z3144510014	14	45	100	14
11Z3164510016	16	45	100	16
11Z3184510018	18	45	100	18
11Z3204510020	20	45	100	20
11Z3086515008	8	65	150	8
11Z3106515010	10	65	150	10
11Z3126515012	12	65	150	12
11Z3146515014	14	65	150	14
11Z3167515016	16	75	150	16
11Z3187515018	18	75	150	18
11Z3207515020	20	75	150	20

12

BALL NOSE CARBIDE ALUMINIUM ENDMILL

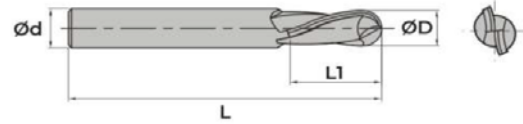

Order Code(Z:2)	Ø D(mm)	L1(mm)	L(mm)	Ø d(mm)
12Z2031205003	3	12	50	3
12Z2041405104	4	14	51	4
12Z2051605105	5	16	51	5
12Z2061905806	6	19	58	6
12Z2082006408	8	20	64	8
12Z2102107310	10	21	73	10
12Z2122508412	12	25	84	12
12Z2143208414	14	32	84	14
12Z2163209316	16	32	93	16
12Z2183509318	18	35	93	18
12Z2203810020	20	38	100	20

13

BALL NOSE LONG CARBIDE ALUMINIUM ENDMILL

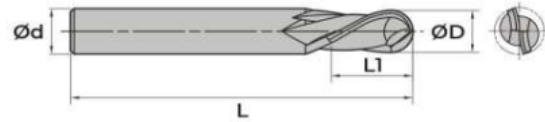

Order Code(Z:2)	$\varnothing D$ (mm)	L_1 (mm)	L (mm)	$\varnothing d$ (mm)
13Z2032007503	3	20	75	3
13Z2042007504	4	20	75	4
13Z2052507505	5	25	75	5
13Z2063007506	6	30	75	6
13Z2083007508	8	30	75	8
13Z2032010003	3	20	100	3
13Z2042010004	4	20	100	4
13Z2052510005	5	25	100	5
13Z2063010006	6	30	100	6
13Z2083010008	8	30	100	8
13Z2104510010	10	45	100	10
13Z2124510012	12	45	100	12
13Z2144510014	14	45	100	14
13Z2164510016	16	45	100	16
13Z2184510018	18	45	100	18
13Z2204510020	20	45	100	20

APPLICATIONS

			$ae = 1.0 \times \varnothing$ $ap(\text{mm}) = 0.5 \times \varnothing$		$ae = 0.5 \times \varnothing$ $ap(\text{mm}) = 1.0 \times \varnothing$		$ae = 0.1 \times \varnothing$ $ap(\text{mm}) = 1.5 \times \varnothing$	
ISO	Material	HB	fz (mm)	Vc m/min	fz (mm)	Vc m/min	fz (mm)	Vc m/min
N	Aluminum Al >99%	30	F0,1	810	F0,2	880	F0,3	950
	Aluminum Wrought or wrought and coldworked, non-aging	60	F0,1	810	F0,2	870	F0,3	940
	Aluminum Wrought or wrought and aged	100	F0,1	730	F0,2	780	F0,3	850
	Aluminum Cast, non-aging	75	F0,1	810	F0,2	870	F0,3	94
	Aluminum Cast or cast and aged	90	F0,1	730	F0,2	790	F0,3	850
	Aluminum Cast, 13-15% Si	130	F0,1	325	F0,2	350	F0,3	380
	Aluminum Cast, 16-22% Si	130	F0,1	245	F0,2	265	F0,3	285
	Copper Free cutting alloys, > 1% Pb	110	F0,1	405	F0,2	435	F0,3	470
	Copper Brass, leaded bronzes, < 1% Pb	90	F0,1	405	F0,2	435	F0,3	470
Copper Bronze and non-lead copper, electrolytic copper	100	F0,1	285	F0,2	305	F0,3	330	

14

CARBIDE ROUGHING ENDMILL

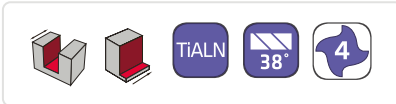
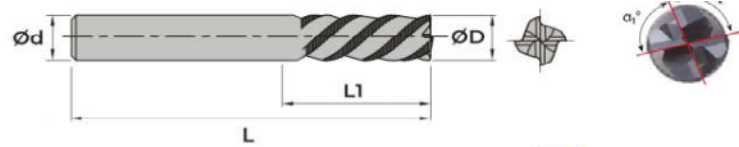

Order Code(Z:4)	$\varnothing D(\text{mm})$	$L1(\text{mm})$	$L(\text{mm})$	$\varnothing d(\text{mm})$
14Z4061905706	6	19	57	6
14Z4082006308	8	20	63	8
14Z4102107210	10	21	72	10
14Z4122508312	12	25	83	12
14Z4143208314	14	32	83	14
14Z4163209216	16	32	92	16
14Z4183509218	18	35	92	18
14Z4209810020	20	38	100	20
14Z4223810022	22	38	100	22
14Z4243810024	24	38	100	24
14Z4253810025	25	38	100	25

15

LONG CARBIDE ROUGHING ENDMILL

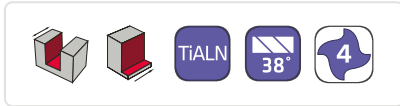
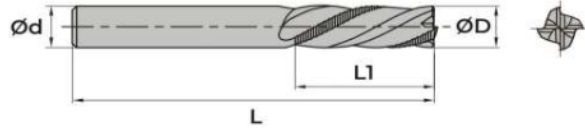

Order Code(Z:4)	Ø D(mm)	L1(mm)	L(mm)	Ø d(mm)
15Z4063010006	6	30	100	6
15Z4083010008	8	30	100	8
15Z4104510010	10	45	100	10
15Z4124510012	12	45	100	12
15Z4144510014	14	45	100	14
15Z4164510016	16	45	100	16
15Z4184510018	18	45	100	18
15Z4204510020	20	45	100	20
15Z4086515008	8	65	150	8
15Z4106515010	10	65	150	10
15Z4126515012	12	65	150	12
15Z4146515014	14	65	150	14
15Z4167515016	16	75	150	16
15Z4187515018	18	75	150	18
15Z4207515020	20	75	150	20
15Z4227515022	22	75	150	22
15Z4247515024	24	75	150	24
15Z4257515025	25	75	150	25

16

CARBIDE FINISHING ENDMILL Z6

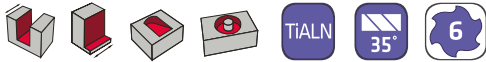
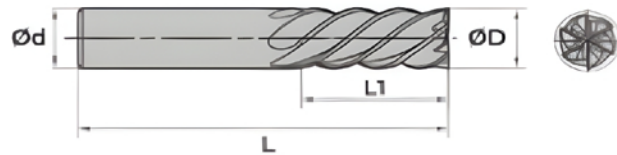

Order Code (Z:6)	ØD(mm)	L1(mm)	L(mm)	Ød(mm)
16Z6061905806	6	19	57	6
16Z6082006408	8	20	63	8
16Z6102107310	10	21	72	10
16Z6122508412	12	25	83	12
16Z6143208414	14	32	83	14
16Z6163209316	16	32	92	16
16Z6183509318	18	35	92	18
16Z6203810020	20	38	100	20
16Z6223810022	22	38	100	22
16Z6243810024	24	38	100	24
16Z6253810025	25	38	100	25

17

LONG CARBIDE FINISHING ENDMILL Z6

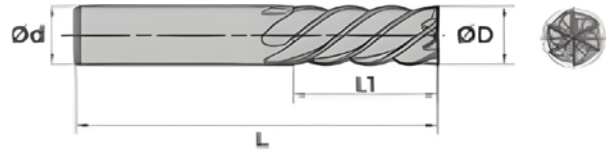

Order Code(Z:6)	ØD(mm)	L1(mm)	L(mm)	Ød(mm)
17Z6063010006	6	30	100	6
17Z6083010008	8	30	100	8
17Z6086515008	8	65	150	8
17Z6106515010	10	65	150	10
17Z6126515012	12	65	150	12
17Z6146515014	14	65	150	14
17Z6167515016	16	75	150	16
17Z6187515018	18	75	150	18
17Z6207515020	20	75	150	20
17Z6227515022	22	75	150	22
17Z6247515024	24	75	150	24
17Z6257515025	25	75	150	25

APPLICATIONS

			FINISHING		
			GROUPS		
			ap(mm) = 2.0 - 4.0 x Ø		
ISO	Material	HB	ap (mm)	fz (mm)	Vc m/min
P	Unalloyed steel	190	0.10(0.05-0.2)	0.03	366
	Low-alloyed steel	240	0.10(0.05-0.2)	0.03	351
	High alloyed steel	320	0.10(0.05-0.2)	0.03	205
	Ferritic/martensitic stainless steel	200	0.10(0.05-0.2)	0.03	176
M	Austenitic stainless steel	200	0.10(0.05-0.2)	0.03	220
	Duplex (austenitic/ferritic) stainless steel	260	0.10(0.05-0.2)	0.03	190
	Malleable cast iron	200	0.10(0.05-0.2)	0.03	344
K	Gray cast iron	180	0.10(0.05-0.2)	0.03	351
	Nodular cast iron	215	0.10(0.05-0.2)	0.03	359
	Aluminium based alloys	100	0.10(0.05-0.2)	0.03	1140
N	Aluminium based alloys	75	0.10(0.05-0.2)	0.03	492
	Aluminium based alloys	130	0.10(0.05-0.2)	0.03	234
	Copper and copper alloys	90	0.10(0.05-0.2)	0.03	294
S	Nickel based superalloys	350	0.10(0.05-0.2)	0.03	50
	Titanium based alloys	320	0.10(0.05-0.2)	0.03	105

18

CARBIDE ROUNDING CONCAVE CUTTER

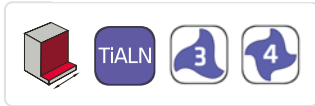
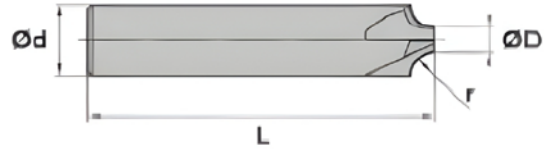

Order Code (Z4)	r(mm)	L(mm)	$\varnothing d$ (mm)
22Z4061006308	1	63	8
22Z4061506709	1,5	67	9
22Z4062007210	2	72	10
22Z4062507511	2,5	75	11
22Z4063008312	3	83	12
22Z4063508313	3,5	83	13
22Z4064008314	4	83	14
22Z4064509215	4,5	92	15
22Z4065009216	5	92	16
22Z4066009218	6	92	18
22Z4068010022	8	100	22

19

CARBIDE T-SLOT ENDMILL

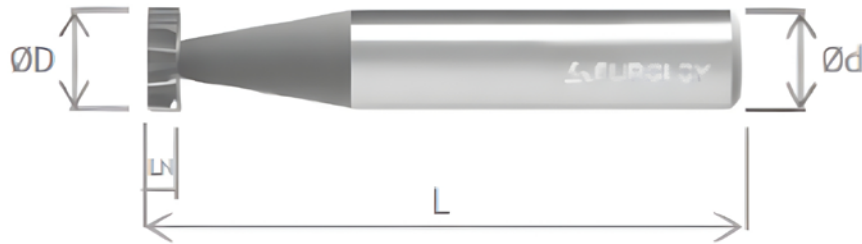

TiAlN

6

8

10

Order Code	ØD (mm)	LN (mm)	L (mm)	d(mm)
23Z60605706LN#	6	1-1,5-2	57	6
23Z60806308LN#	8	1-1,5-2-2,5-3	63	8
23Z61007210LN#	10	2-2,5-3-4-5-6	72	10
23Z81208312LN#	12	2-2,5-3-4-5-6	83	12
23Z81408314LN#	14	2-2,5-3-4-5-6	83	14
23Z81609216LN#	16	2-2,5-3-4-5-6	92	16
23Z81809218LN#	18	2-2,5-3-4-5-6	92	18
23Z82010020LN#	20	2-2,5-3-4-5-6	100	20
23Z82210022LN#	22	2-2,5-3-4-5-6	100	22
23Z82410024LN#	24	2-2,5-3-4-5-6	100	24
23Z82510025LN#	25	2-2,5-3-4-5-6	100	25

20

3D CARBIDE DRILL

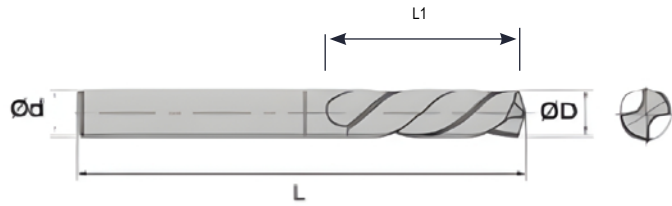

Order Code	ØD(mm)	L1 (mm)	L(mm)	Ød(mm)
250303D04603	3,0	16	46	3
250313D05504	3,1	18	55	4
250323D05504	3,2	18	55	4
250333D05504	3,3	18	55	4
250343D05504	3,4	18	55	4
250353D05504	3,5	20	55	4
250363D05504	3,6	20	55	4
250373D05504	3,7	20	55	4
250383D05504	3,8	20	55	4
250393D05504	3,9	20	55	4
250403D06205	4,0	22	62	5
250413D06205	4,1	22	62	5
250423D06205	4,2	22	62	5
250433D06205	4,3	22	62	5
250443D06205	4,4	22	62	5
250453D06205	4,5	24	62	5
250463D06205	4,6	24	62	5
250473D06205	4,7	24	62	5
250483D06205	4,8	24	62	5
250493D06205	4,9	24	62	5
250503D06205	5,0	26	62	5
250513D06606	5,1	26	66	6
250523D06606	5,2	26	66	6
250533D06606	5,3	26	66	6
250543D06606	5,4	26	66	6
250553D06606	5,5	28	66	6

20

3D CARBIDE DRILL

Order Code	ØD(mm)	L1 (mm)	L(mm)	Ød(mm)
250563D06606	5,6	28	66	6
250573D06606	5,7	28	66	6
250583D06606	5,8	28	66	6
250593D06606	5,9	28	66	6
250603D06606	6,0	28	66	6
250613D07407	6,1	31	74	7
250623D07407	6,2	31	74	7
250633D07407	6,3	31	74	7
250643D07407	6,4	31	74	7
250653D07407	6,5	31	74	7
250663D07407	6,6	31	74	7
250673D07407	6,7	31	74	7
250683D07407	6,8	31	74	7
250693D07408	6,9	34	74	8
250703D07408	7,0	34	74	8
250713D07908	7,1	34	79	8
250723D07908	7,2	34	79	8
250733D07908	7,3	34	79	8
250743D07908	7,4	34	79	8
250753D07908	7,5	34	79	8
250763D07908	7,6	37	79	8
250773D07908	7,7	37	79	8
250783D07908	7,8	37	79	8
250793D07908	7,9	37	79	8
250803D07908	8,0	37	79	8
250813D08409	8,1	37	84	9
250823D08409	8,2	37	84	9
250833D08409	8,3	37	84	9
250843D08409	8,4	37	84	9
250853D08409	8,5	37	84	9
250863D08409	8,6	40	84	9
250873D08409	8,7	40	84	9
250883D08409	8,8	40	84	9
250893D08409	8,9	40	84	9
250903D08410	9,0	40	84	10
250913D08910	9,1	40	89	10

20

3D CARBIDE DRILL

Order Code	ØD(mm)	L1 (mm)	L(mm)	Ød(mm)
250923D08910	9,2	40	89	10
250933D08910	9,3	40	89	10
250943D08910	9,4	40	89	10
250953D08910	9,5	40	89	10
250963D08910	9,6	43	89	10
250973D08910	9,7	43	89	10
250983D08910	9,8	43	89	10
250993D08910	9,9	43	89	10
251003D08910	10	43	89	10
251053D09511	10,5	43	95	11
251103D09511	11	47	95	11
251153D10212	11,5	47	102	12
251203D10212	12	51	102	12
251253D10213	12,5	51	102	13
251303D10213	13	51	102	13
251353D10714	13,5	51	107	14
251403D10714	14	54	107	14
251453D11115	14,5	54	111	15
251503D11115	15	56	111	15
251553D11516	15,5	56	115	16
251603D11516	16	58	115	16
251653D11517	16,5	58	115	17
251703D11517	17	58	115	17
251753D11518	17,5	62	115	18
251803D12318	18	62	123	18
251853D12319	18,5	62	123	19
251903D12319	19	62	123	19
251953D13120	19,5	66	131	20
252003D13120	20	66	131	20

20

3D CARBIDE DRILL

Cutting Parameters Vc(m/min)

P	Non-Alloy Steel	80-105	●
	Steel	80-100	●
	Tempered Steel	80-100	●
	Cold-Work Tool Steel	60-80	○
	Hot-Work Tool Steel	60-80	○
M	AISI 304 - 416 - 420	30-40	○
	AISI 316 - 440	30-40	○
	17-4 PH 15-5 PH	25-30	○
	Chrome-Cobalt Alloy	25-30	○
	Duplex F51	15-25	○
K	Super Duplex F55	15-25	○
	Grey Cast Iron	140-170	●
	Alloy Cast Iron	100-130	●
S	Precision Cast	80-110	●
	Titanium	30-40	○
H	Titanium Alloys	25-30	○
	≤54 HRc	60-80	○
	> 54 HRc	40-55	○

Feed Per Revolution (mm/rev)

Ø	
3	0,025
4	0,03
5	0,042
6	0,052
7	0,082
8	0,12
9	0,140
10	0,16
12	0,190
14	0,22
16	0,240
18	0,26
20	0,290

21

5D CARBIDE DRILL

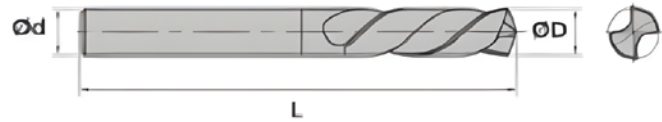

Order Code	ØD(mm)	L1 (mm)	L(mm)	Ød(mm)
260305D06606	3,0	23	66	6
260315D06606	3,1	23	66	6
260325D06606	3,2	23	66	6
260335D06606	3,3	23	66	6
260345D06606	3,4	23	66	6
260355D06606	3,5	23	66	6
260365D06606	3,6	23	66	6
260375D06606	3,7	23	66	6
260385D07706	3,8	29	77	6
260395D07706	3,9	29	77	6
260405D07706	4,0	29	77	6
260415D07706	4,1	29	77	6
260425D07706	4,2	29	77	6
260435D07706	4,3	29	77	6
260445D07706	4,4	29	77	6
260455D07706	4,5	29	77	6
260465D07706	4,6	29	77	6
260475D08206	4,7	29	82	6
260475D08206	4,8	35	82	6
260495D08206	4,9	35	82	6
260505D08206	5,0	35	82	6
260515D08206	5,1	35	82	6
260525D08206	5,2	35	82	6
260535D08206	5,3	35	82	6
260545D08206	5,4	35	82	6
260555D08206	5,5	35	82	6

21

5D CARBIDE DRILL

Order Code	ØD(mm)	L1 (mm)	L(mm)	Ød(mm)
260565D08206	5,6	35	82	6
260575D08206	5,7	35	82	6
260585D08206	5,8	35	82	6
260595D08206	5,9	35	82	6
260605D08206	6,0	35	82	6
260615D09108	6,1	43	91	8
260625D09108	6,2	43	91	8
260635D09108	6,3	43	91	8
260645D09108	6,4	43	91	8
260655D09108	6,5	43	91	8
260665D09108	6,6	43	91	8
260675D09108	6,7	43	91	8
260685D09108	6,8	43	91	8
260695D09108	6,9	43	91	8
260705D09108	7,0	43	91	8
260715D09108	7,1	43	91	8
260725D09108	7,2	43	91	8
260735D09108	7,3	43	91	8
260745D09108	7,4	43	91	8
260755D09108	7,5	43	91	8
260765D09108	7,6	43	91	8
260775D09108	7,7	43	91	8
260785D09108	7,8	43	91	8
260795D09108	7,9	43	91	8
260805D09108	8,0	43	91	8
260815D10310	8,1	49	103	10
260825D10310	8,2	49	103	10
260835D10310	8,3	49	103	10
260845D10310	8,4	49	103	10
260855D10310	8,5	49	103	10
260865D10310	8,6	49	103	10
260875D10310	8,7	49	103	10
260885D10310	8,8	49	103	10
260895D10310	8,9	49	103	10
260905D10310	9,0	49	103	10
260915D10310	9,1	49	103	10

21

5D CARBIDE DRILL

Order Code	ØD(mm)	L1 (mm)	L(mm)	Ød(mm)
260925D10310	9,2	49	103	10
260935D10310	9,3	49	103	10
260945D10310	9,4	49	103	10
260955D10310	9,5	49	103	10
260965D10310	9,6	49	103	10
260975D10310	9,7	49	103	10
260985D10310	9,8	49	103	10
260995D10310	9,9	49	103	10
261005D10310	10	49	103	10
261055D11812	10,5	56	118	12
261105D11812	11,0	56	118	12
261155D11812	11,5	56	118	12
261205D11812	12,0	56	118	12
261265D12414	12,5	60	124	14
261305D12414	13,0	60	124	14
261355D12414	13,5	60	124	14
261405D12414	14,0	60	124	14
261455D13316	14,5	63	133	16
261505D13316	15,0	63	133	16
261555D13316	15,5	63	133	16
261605D13316	16,0	63	133	16
261655D14318	16,5	71	143	18
261705D14318	17,0	71	143	18
261755D14318	17,5	71	143	18
261805D14318	18,0	71	143	20
261855D15320	18,5	77	153	20
261905D15320	19,0	77	153	20
261955D15320	19,5	77	153	20
262005D15320	20,0	77	153	20

21

5D CARBIDE DRILL

Cutting Parameters Vc(m/min)

P	Non-Alloy Steel	110-125	●
	Steel	100-120	●
	Tempered Steel	100-120	●
	Cold-Work Tool Steel	70-90	○
	Hot-Work Tool Steel	70-90	○
M	AISI 304 - 416 - 420	55-65	○
	AISI 316 - 440	55-65	○
	17-4 PH 15-5 PH	50-55	○
	Chrome-Cobalt Alloy	50-55	○
	Duplex F51	40-50	○
	Super Duplex F55	40-50	○
K	Grey Cast Iron	170-200	●
	Alloy Cast Iron	130-150	●
	Precision Cast	110-130	●
S	Titanium	55-65	○
	Titanium Alloys	55-65	○
H	≤54 HRc	60-80	○
	> 54 HRc	40-55	○

Feed Per Revolution (mm/rev)

∅	
3	0,03
4	0,045
5	0,85
6	0,17
7	0,19
8	0,21
9	0,23
10	0,25
12	0,27
14	0,29
16	0,31
18	0,33
20	0,35

22

CARBIDE MICRO DRILL

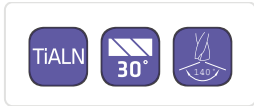
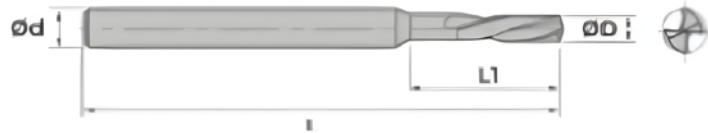

Order Code	ØD(mm)	L1 (mm)	L(mm)	Ød(mm)
2701000805003	1	8	50	3
2701100805003	1,1	8	50	3
2701200805003	1,2	8	50	3
2701300805003	1,3	8	50	3
2701401005003	1,4	10	50	3
2701500805003	1,5	10	50	3
2701600805003	1,6	10	50	3
2701700805003	1,7	10	50	3
2701800805003	1,8	12	50	3
2701900805003	1,9	12	50	3
2702000805003	2	12	50	3
2702101205003	2,1	12	50	3
2702201205003	2,2	12	50	3
2702301405003	2,3	14	50	3
2702401405003	2,4	14	50	3
2702501405003	2,5	14	50	3
2702601405003	2,6	14	50	3
2702701405003	2,7	14	50	3
2702801405003	2,8	14	50	3
2702901405003	2,9	14	50	3

Solid Carbide Tools

23

EXTRA LONG CARBIDE DRILL

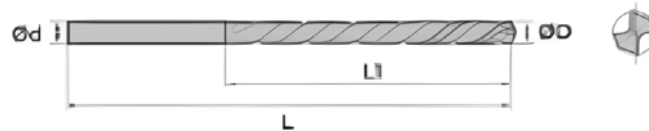

Order Code	ØD(mm)	L1 (mm)	L (mm)	Ød(mm)
2803003306104	3	33	61	4
2803103307504	3,1	33	75	4
2803203307504	3,2	33	75	4
2803303307504	3,3	33	75	4
2803403307504	3,4	33	75	4
2803503907504	3,5	39	75	4
2803603907504	3,6	39	75	4
2803703907504	3,7	39	75	4
2803803907504	3,8	39	75	4
2803903907504	3,9	39	75	4
2804004307504	4	43	75	4
2804104308605	4,1	43	86	5
2804204308605	4,2	43	86	5
2804304308605	4,3	43	86	5
2804404308605	4,4	43	86	5
2804504708605	4,5	47	86	5
2804604708605	4,6	47	86	5
2804704708605	4,7	47	86	5
2804804708605	4,8	47	86	5
2804904708605	4,9	47	86	5
2805005208605	5	52	86	5
2805105209306	5,1	52	93	6
2805205209306	5,2	52	93	6
2805305209306	5,3	52	93	6
2805405209306	5,4	52	93	6
2805505709306	5,5	57	93	6

23

EXTRA LONG CARBIDE DRILL

Order Code	ØD(mm)	L1 (mm)	L (mm)	Ød(mm)
2805605709306	5,6	57	93	6
2805705709306	5,7	57	93	6
2805805709306	5,8	57	93	6
2805905709306	5,9	57	93	6
2806005709306	6	57	93	6
2806105710907	6,1	57	109	7
2806205710907	6,2	57	109	7
2806305710907	6,3	57	109	7
2806405710907	6,4	57	109	7
2806506310907	6,5	63	109	7
2806606310907	6,6	63	109	7
2806706310907	6,7	63	109	7
2806806310907	6,8	63	109	7
2806906310907	6,9	63	109	7
2807006310907	7	63	109	7
2807106911708	7,1	69	117	8
2807206911708	7,2	69	117	8
2807306911708	7,3	69	117	8
2807406911708	7,4	69	117	8
2807506911708	7,5	69	117	8
2807606911708	7,6	69	117	8
2807706911708	7,7	69	117	8
2807806911708	7,8	69	117	8
2807906911708	7,9	69	117	8
2808007511708	8	75	117	8
2808107512509	8,1	75	125	9
2808207512509	8,2	75	125	9
2808307512509	8,3	75	125	9
2808407512509	8,4	75	125	9
2808507512509	8,5	75	125	9
2808607512509	8,6	75	125	9
2808707512509	8,7	75	125	9
2808807512509	8,8	75	125	9
2808907512509	8,9	75	125	9
2809008112509	9	81	125	9

23

EXTRA LONG CARBIDE DRILL

Order Code	ØD(mm)	L1 (mm)	L (mm)	Ød(mm)
2809108113310	9,1	81	133	10
2809208113310	9,2	81	133	10
2809308113310	9,3	81	133	10
2809408113310	9,4	81	133	10
2809508113310	9,5	81	133	10
2809608113310	9,6	81	133	10
2809708113310	9,7	81	133	10
2809808113310	9,8	81	133	10
2809908113310	9,9	81	133	10
2810008713310	10	87	133	10
2810508714211	10,5	87	142	11
2811008414211	11	94	142	11
2811509415112	11,5	94	151	12
2812010115112	12	101	151	12
2812510115113	12,5	101	151	13
2813010115113	13	101	151	13
2813510115114	13,5	101	151	14
2814010115114	14	101	151	14

23

EXTRA LONG CARBIDE DRILL

Cutting Parameters Vc(m/min)

P	Non-Alloy Steel	80-105	●
	Steel	70-100	●
	Tempered Steel	70-95	●
	Cold-Work Tool Steel	50-80	●
	Hot-Work Tool Steel	50-80	●
M	AISI 304 - 416 - 420	50-55	○
	AISI 316 - 440	50-55	○
	17-4 PH 15-5 PH	40-50	○
	Chrome-Cobalt Alloy	40-50	○
	Duplex F51	30-40	○
K	Super Duplex F55	30-40	○
	Grey Cast Iron	140-170	●
	Alloy Cast Iron	110-140	●
S	Precision Cast	80-110	●
	Titanium	50-70	○
H	Titanium Alloys	40-60	○
	≤54 HRc	60-80	○
	> 54 HRc	40-55	○

Feed Per Revolution (mm/rev)

Ø	
3	0,112
4	0,119
5	0,126
6	0,140
7	0,154
8	0,168
9	0,189
10	0,210
12	0,231
14	0,252
16	0,273
18	0,294
20	0,315

Engineered for Excellence.

#EuroloyExcellence



Italy Office



Via Leonardo Da Vinci, 4 – 20054
Milano MI ITALIA



(+39) 0282398309



info@euroloy.com

Turkey Office



Üsküdar Cad. YEDPA No:1
Ataşehir -İstanbul -TÜRKİYE



(+90) 850 933 3408



euroloytr@euroloy.com



euroloytools



Euroloy Cutting Tools